



**Protege Wireless Lock Range**

# **Cartridge Mortise Wireless Lock**

Installation Manual



The specifications and descriptions of products and services contained in this document were correct at the time of printing. Integrated Control Technology Limited reserves the right to change specifications or withdraw products without notice. No part of this document may be reproduced, photocopied, or transmitted in any form or by any means (electronic or mechanical), for any purpose, without the express written permission of Integrated Control Technology Limited. Designed and manufactured by Integrated Control Technology Limited, Protege® and the Protege® Logo are registered trademarks of Integrated Control Technology Limited. All other brand or product names are trademarks or registered trademarks of their respective holders.

Copyright © Integrated Control Technology Limited 2003-2024. All rights reserved.

Last Published: 22-Feb-24 1:18 PM

# Contents

<b>Introduction</b>	<b>5</b>
About This Product	5
How Does It Work?	5
<b>Hardware Options</b>	<b>7</b>
Construction Cards	8
Replacement Parts	9
Key Cylinder	9
<b>MIFARE Technology</b>	<b>10</b>
About MIFARE	10
Secured MIFARE Card Format	10
About MIFARE DESFire EV1	10
About MIFARE DESFire EV2	10
About MIFARE DESFire EV3	11
MIFARE/DESFire Products	11
<b>Installation Requirements</b>	<b>12</b>
<b>Installation</b>	<b>13</b>
Installation Overview	14
What's Included?	15
Door Preparation	15
Installing the Strike Plate	16
Installing the Lock	17
Position the Lock Cable	17
Secure the Lock	18
Fit the Handle and Sectional Trim	19
Key Cylinder and Privacy Thumbturn	21
Installing the Faceplate	22
Installing the Lock Control Cartridge	23
Position the Reader Cable	23
Connect the Lock Cable	24
Secure the Cartridge	25
Installing the Reader	26
Connect the Reader	26
Attach the Reader	27
Inserting the Batteries	28
Installing the DPS Magnet	29

Programming Locks	30
Operation	31
Maintenance	33
Mechanical Layout	34
Door Template	35
Technical Specifications	37
UL and cUL Installation Requirements	39
CAN/ULC-60839-11-1	39
UL 294	39
UL 1034	39
Flammability Standards	40
FCC Compliance Statements	41
Industry Canada Statement	42
Disclaimer and Warranty	43

# Introduction

This installation manual provides instructions and technical specifications for installation of the Protege Cartridge Mortise Wireless Lock.

For programming instructions, see the Protege Wireless Lock Configuration Guide.

## About This Product

The Protege Cartridge Mortise Wireless Lock combines an advanced-technology, intelligent wireless credential reader with leading mortise locking system technology. With no cabling necessary this provides sites with the ability to deploy integrated electronic access control in areas where traditional wired locking solutions may not be possible.

Current features of the wireless lock include:

- **Bluetooth®** Wireless Technology
- MIFARE, DESFire and mobile credential reading
- Integrated LED indicator provides read response and status signaling
- USB-C connection to supply power for emergency opening
- Lock configuration programmable via the Protege Config App
- Efficient operation provides up to 2 years of battery life\* (40,000 activations)

\*Not evaluated by UL.

## How Does It Work?

Unlike wired doors, which contact the controller to determine whether to grant or deny access, offline wireless locks make access decisions based on the permissions stored on the user's credential ('data on card').

In an offline wireless locking system each user acts as a walking data store carrying access and event data to and from the locks, like a colony of ants creating a mobile data network.

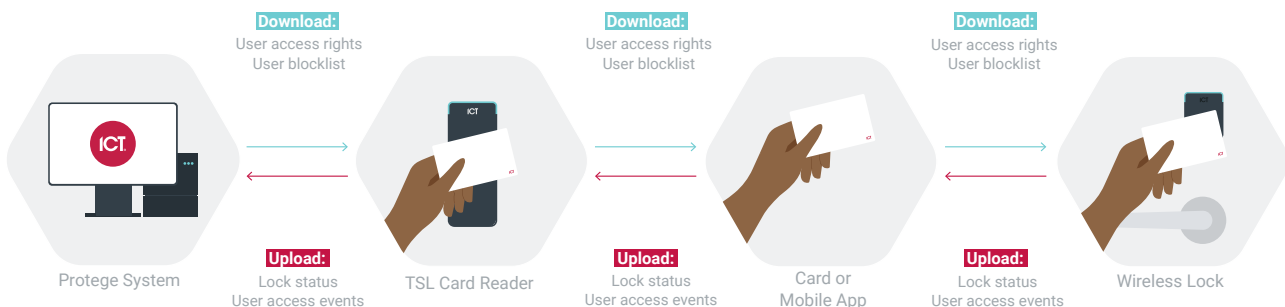

When a user presents their credential at a wired update point (such as at a main entrance) the reader downloads a 'credential blob' to the card/phone. This credential blob contains encrypted information about the access rights for that specific credential, including which doors they can access and when. It also includes a blacklist of users who have recently been banned from the site.

When the user presents their credential at a wireless lock the credential blob tells the lock whether that user should be granted or denied access. All the lock has to do is follow the instructions. The blacklist is also uploaded to the lock to ensure that inactive users who have not yet had their credential blob updated can no longer gain access. At the same time the lock downloads the user's events to their credential, and when they next present at a wired update point their accumulated events are uploaded to the controller.

Access-related programming changes to access levels, schedules and so on are downloaded to the controller as normal. The next time the user presents the credential at a wired update point the credential blob is updated with any changes that affect their access for that specific credential.

# Hardware Options

---

The Protege Cartridge Mortise Wireless Lock offers the flexibility to create your own configuration. Simply choose your preferred components from the range of available options to compile your perfect combination.

1. Select the **Electronic Cartridge**.
2. Choose a **Reader Cover**.
3. Select the **Mortise Lock Body** type.
4. Specify the **Handing**.
5. Select the optional **Thumbturn** if required.
6. Select a **Handle Set**.
7. Select the **Sectional Trim**.
8. Specify the **Finish**.

## Cartridge Mortise Wireless Lock Options

Electronic Cartridge	Code
Mortise Electronic Cartridge & Reader with Door Position Sensor	CME-DFBT

Door position sensor is not evaluated by UL/cUL.

Reader Cover	Code
Black Circular	MC-BC
Black Rectangular	MC-BR
White Circular	MC-WC
White Rectangular	MC-WR

Mortise Lock Body	Code
Mortise Lock Body (with Optional Thumbturn)	MLB
Mortise Lock Body with Deadbolt and Thumbturn	MLB-DB

Handing	Code
Left Hand	LH
Right Hand	RH
Left Hand Reverse	LHR
Right Hand Reverse	RHR

Optional Thumbturn	Code
Mortise Thumbturn	MT

Handle Set	Code
Acadia	MH-AC
Aspiring*	MH-AS
Banff	MH-BA
Denali	MH-DE
Glacier	MH-GL
Jasper	MH-JP
Nightcap	MH-NI
Peak	MH-PE
Sequoia	MH-SE

\* Handing needs to be specified when ordering the Aspiring handle set. Other handles are non-handed.

Sectional Trim	Code
Round Rose	MR-RO
Square Rose	MR-SQ

Finish	Code
Bright Brass Clear Coated	605-BB
Satin Brass Clear Coated	606-SB
Satin Bronze Clear Coated	612-SB
Oil Rubbed Bronze	613-RB
Flat Black	622-FB
Bright Stainless Steel	629-BS
Satin Stainless Steel	630-SS

Color selection applies to faceplate, strike plate, handle, trim, thumbturn and cartridge armor plate. By default, all parts have the same finish. For split finishes, contact ICT Customer Support to make a custom order.

## Construction Cards

When a Protege wireless lock is in factory default state, it can only be unlocked using a construction card provided by ICT. Construction cards are also used to initialize locks and connect them to the access control system.

Construction cards are not included with the locks and must be ordered separately. Any ICT construction card will work with any Protege wireless lock.

Card	Code
ICT Construction Card	WL-CONST



## Replacement Parts

In addition to the components included in the initial installation, the following individual components may be ordered for replacement.

The required finish will need to be specified when ordering replacement parts.

Mortise Lock Strike Plate Replacement	Code
Mortise Strike Plate	SPM

Mortise Lock Faceplate Replacement	Code
Mortise Dress Plate (no Deadbolt)	DPM
Mortise Dress Plate (with Deadbolt)	DPM-DB

Electronic Lock Control Cartridge Armor Plate Replacement	Code
Cartridge Dress Plate	DPC

## Key Cylinder

The mortise lock mechanism contains space for an optional key cylinder. A suitable 1 ¼" mortise key cylinder may be obtained from a third-party supplier.

# MIFARE Technology

---

## About MIFARE

Based on the international standard ISO/IEC 14443 Type A, MIFARE is a technology used for contactless RFID smart card systems consisting of card and reader components.

- Fully compliant with the international standard ISO/IEC 14443 Type A
- Multi-application memory to store several services on the same card, allowing for many integration possibilities
- Fast transaction speed
- High security and fraud protection

## Secured MIFARE Card Format

Secured MIFARE is the compromise between secured cards and cost. Card data is protected with a diversified authentication key and encrypted with an AES256 algorithm. These cards are not as secure as MIFARE DESFire but still provide high security against cloning. This card mode can be used on all MIFARE 1K (S50) cards and tags.

## About MIFARE DESFire EV1

MIFARE DESFire EV1 is an ideal solution for multi-application smart cards in transport schemes, e-government or identity applications. It complies fully with the requirements for fast and highly secure data transmission, flexible memory organization, and interoperability with existing infrastructure.

- Fully compliant with the international standard ISO/IEC 14443 Type A 1-4
- Common Criteria EAL4+ security certified
- Secure, high speed command set
- Unique 7-byte serial number
- Open DES/3DES crypto algorithm in hardware
- Open AES 128 bit crypto algorithm in hardware

## About MIFARE DESFire EV2

MIFARE DESFire EV2 delivers the perfect balance of speed, performance and cost-efficiency. For a truly convenient touch-and-go experience, MIFARE DESFire EV2 offers increased operating distance.

Based on global open standards for both air interface and cryptographic methods, it complies with all requirements for fast and highly secure data transmission and flexible application management.

- Fully compliant with all levels of the international standard ISO/IEC 14443A
- Common Criteria EAL5+ security certified
- Secure, high speed command set
- Unique 7-byte serial number
- Open DES/3DES crypto algorithm in hardware
- Open AES 128 bit crypto algorithm in hardware
- Fully interoperable with existing NFC reader infrastructure
- Backwards compatible with all previous MIFARE DESFire generations

## About MIFARE DESFire EV3

The latest addition to the MIFARE DESFire product family, MIFARE DESFire EV3 offers even more advanced hardware and software implementation on a brand new internal chip, and combines enhanced performance with a greater operating distance and improved transaction speed compared to its predecessors.

Based on global open standards for both air interface and cryptographic methods, it uses the same security certification level as IC products used for banking cards and electronic passports. Featuring an on-chip backup management system and mutual three-pass authentication, EV3 supports confidential and integrity-protected communication with secure dynamic messaging and mirroring.

- Fully compliant with the international standard ISO/IEC 14443 Type A 1-4 and ISO/IEC 7816-4
- Common Criteria EAL5+ security certified for IC hardware and software
- NFC Forum Tag Type 4 certified
- Secure, high speed command set
- Unique 7-byte serial number
- Choice of open DES/2K3DES/3K3DES/AES crypto algorithms
- Open AES 128 bit crypto algorithm in hardware
- Fully interoperable with existing NFC reader infrastructure
- Transaction timer mitigates risk of man-in-the-middle attacks
- Backwards compatible with all previous MIFARE DESFire generations

## MIFARE/DESFire Products

The MIFARE/DESFire products can be expanded to accommodate large numbers of modules using the encrypted RS-485 Network. ICT provides a number of reader and physical credential options in the MIFARE/DESFire range.

### Physical Credentials

- Proximity clamshell card
- Proximity ISO card
- Proximity ISO dual technology card
- Proximity standard key tag
- Proximity adhesive disc
- Proximity silicone wristband

Physical credentials are available in an extensive range of technology and EEPROM size configurations. Visit the ICT website to view the full range of proximity products.

For more information on configuration options and ordering, contact ICT Customer Services.

# Installation Requirements

---

This equipment is to be installed in accordance with:

- The product installation instructions
- UL 294 - Access Control System Units
- UL 681 - Installation and Classification of Burglar and Holdup Systems
- UL 827 - Central-Station Alarm Services
- UL 1034 - Burglary-Resistant Electric Locking Mechanisms
- CAN/ULC-S301, Central and Monitoring Station Burglar Alarm Systems
- CAN/ULC-S302, Installation and Classification of Burglar Alarm Systems for Financial and Commercial Premises, Safes and Vaults
- CAN/ULC-S561, Installation and Services for Fire Signal Receiving Centres and Systems
- CAN/ULC-60839-11-1, Alarm and Electronic Security Systems – Part 11-1: Electronic Access Control Systems – System and Components Requirements
- The National Electrical Code, ANSI/NFPA 70
- The Canadian Electrical Code, Part I, CSA C22.1
- The Local Authority Having Jurisdiction (AHJ)

# Installation

---

Installation of the wireless lock requires the following steps to be completed in the correct sequence.

1. **Install the strike plate** (see page 16).
2. **Install the lock.**
  - Position the lock cable (see page 17).
  - Secure the lock (see page 18).
3. **Fit the handle and sectional trim** (see page 19).
4. If included, **fit the optional key cylinder and privacy thumbturn** (see page 21).
5. **Install the faceplate** (see page 22).
6. **Install the lock control cartridge.**
  - Position the reader cable (see page 23).
  - Connect the lock cable (see page 24).
  - Secure the cartridge (see page 25).
7. **Install the reader.**
  - Attach the reader base (see page 27).
  - Connect the reader (see page 26).
8. **Insert the batteries** (see page 28).
9. **Install the DPS magnet** (see page 29).

Be careful not to overtighten screws, as this can compress precise moving parts and interfere with the lock operation. It is recommended to always perform the final 10% of tightening by hand.

# Installation Overview

The following image provides a general overview of the lock installation, the components and their positioning.

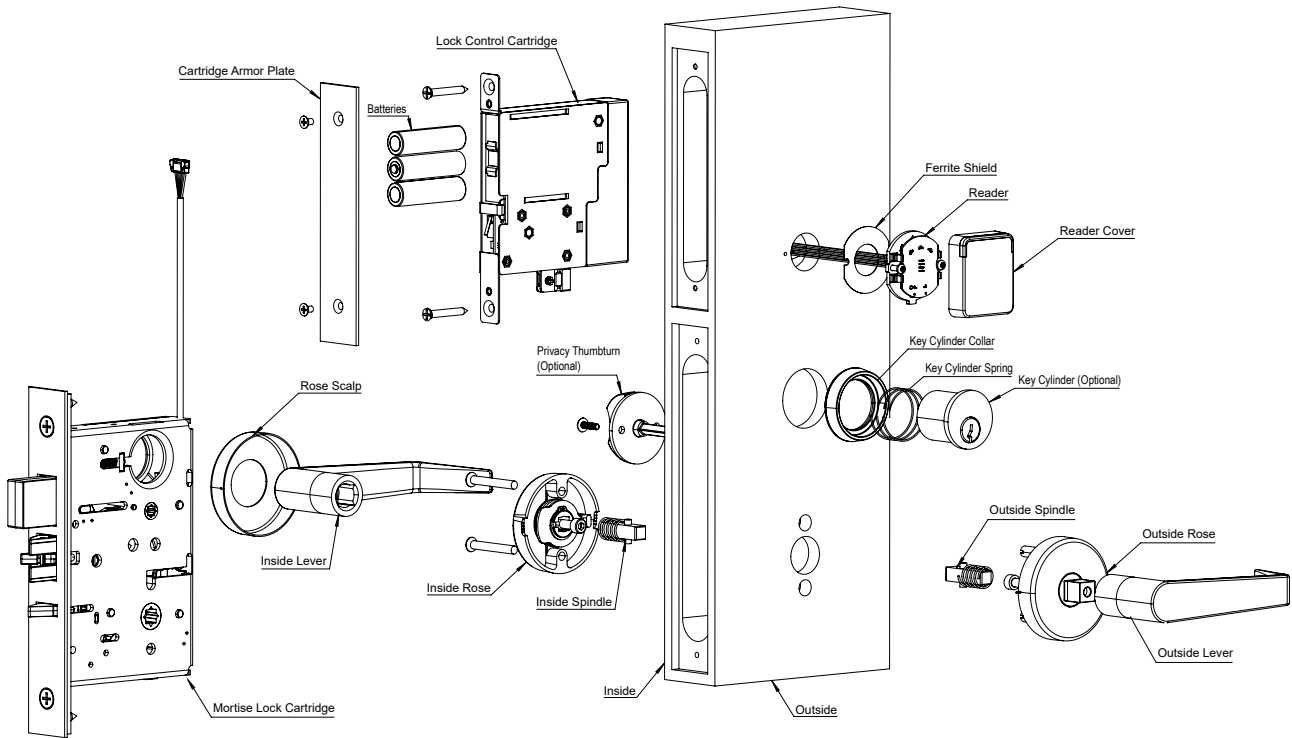

The above diagram is for illustration purposes only. Installation options such as deadbolt, thumbturn, handle style and reader cover options are dependent on the hardware variations installed.

## What's Included?

The Protege Cartridge Mortise Wireless Lock is supplied with the following components.

- 1 x 13.56MHz lock control credential reader with Bluetooth® Wireless Technology
  - USB-C connection to supply power for emergency opening
  - 1 x Reader cover (rectangular or circular)
  - 1 x Reader mounting base
  - 1 x Ferrite shield
  - 2 x N°4 9.5mm pan head self-tapping screws for mounting the reader base
- 1 x Electronic lock control cartridge
  - 8-wire reader cable wiring loom with socket plug for connection to the reader
  - 1 x Armor plate
  - 2 x Countersunk G8 x 3/4" flat head screws for securing the cartridge body
  - 2 x Countersunk #8-32 x 1/4" screws for installing the armor plate
  - 3 x Alkaline AA 1.5V batteries
- 1 x Grade 1 mortise lock
  - 8-wire lock cable wiring loom with socket plug for connection to the lock control cartridge
  - 1 x Faceplate
  - 2 x Countersunk #12-24 combo screws for securing the lock body
  - 2 x Countersunk #8-32 x 1/4" flat head machine screws for installing the faceplate
  - 1 x Deadlatch plate and strike plate
  - 2 x #12-24 combo screws for installing the strike plate
- 1 x Door handle kit with sectional trim
- Optional thumbturn
- Door position sensor magnet

## Door Preparation

Doors should be ordered according to the drill template so that they come pre-prepped from the supplier.

### Door Thickness

1 3/4" (larger thickness available by special order)

### Strike Prep

The mortise lock uses a non-handed curved lip with a deadlatch plate which retracts the deadlatch. The strike prep must be prepared in accordance with the drill template.

### Drill Template

Drill templates should be used to ensure correct installation. Any deviation from the template can result in the lock not functioning correctly.

A to-scale drill template is supplied with the lock and is also available from [www.ict.co/cartridge-mortise-template](http://www.ict.co/cartridge-mortise-template).

## Installing the Strike Plate

1. Prepare the door jamb for the mortise lock strike plate.
2. Install the deadlatch plate behind the strike plate, with the **slider towards the bottom**.

The deadlatch retracts when it hits the deadlatch plate, locking the latch in place and preventing the lock from being tampered or jimmied.

3. Using the two #12-24 combo screws provided, secure the deadlatch plate and strike plate in position.

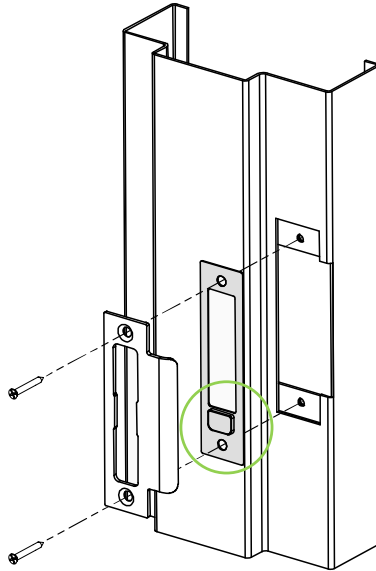



# Installing the Lock

## Position the Lock Cable

Before the mortise lock can be installed the lock cable needs to be threaded through from the lock cavity to the cartridge cavity. This cannot be done after the lock is installed.

1. Remove the two securing screws to remove the faceplate from the lock body.
2. Feed the lock cable in through the lock cavity and up through the cable hole into the cartridge cavity.

It may be helpful to attach a semirigid wire to the lock cable connector plug and pull the lock cable up through the cable hole (see below).

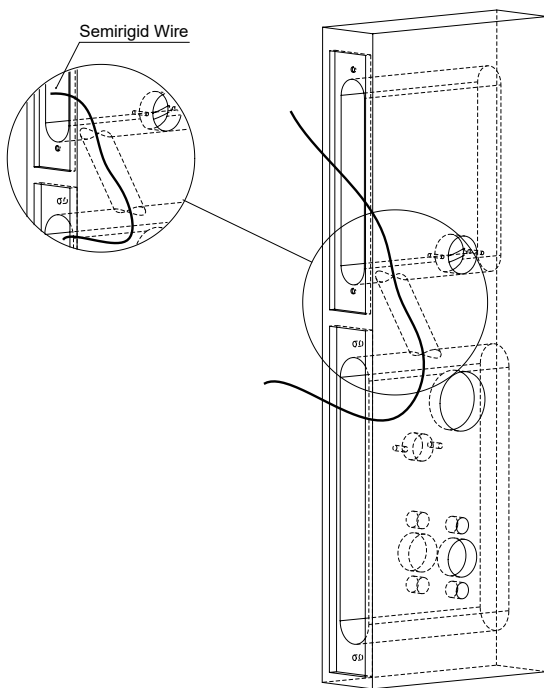

Pass the wire through the cable hole.

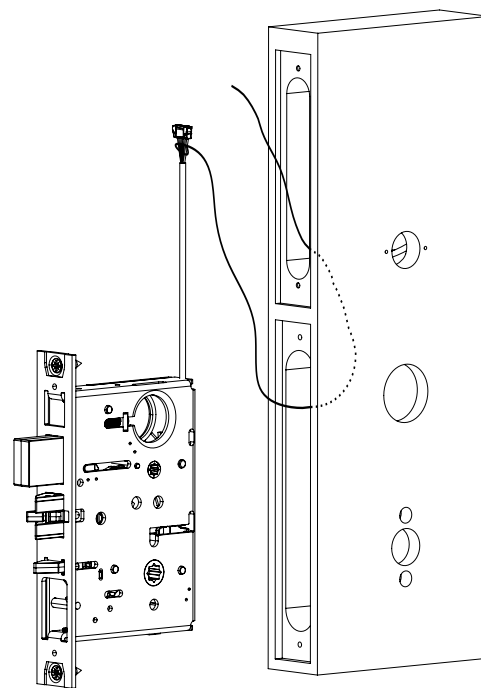

Attach the wire to the lock cable.

## Secure the Lock

1. Insert the mortise lock cartridge into the lock cavity, ensuring the cable remains in position.
2. Using the two #12-24 combo screws provided, secure the lock body in position.

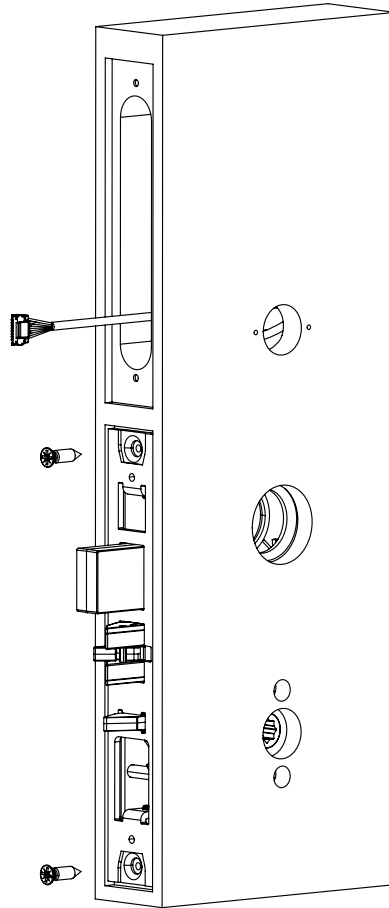

## Fit the Handle and Sectional Trim

Assemble the handle and sectional trim, ensuring the correct inside/outside door and handle positions and spindle orientation.

Levers need to be firmly secured to prevent loose handles. The cap screws can be difficult to tighten sufficiently with hex keys alone, so a T-handle or pliers may be helpful for securing the handles.

1. Assemble the outside rose.
  - i. Fit the rose scalp cover onto the outside rose assembly by aligning the dimples with the slots in the rose plate. Secure by rotating clockwise until tight.
  - ii. Fit the handle onto the rose assembly spindle.
  - iii. Using the M5 x 0.8 x 14mm socket head cap screw and 4mm hex key provided, secure the handle.

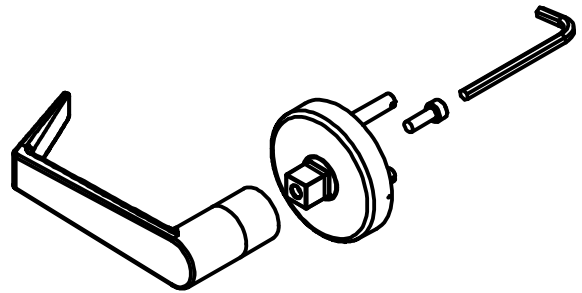

2. Assemble the inside rose.

This step is **not required** for Aspiring and Jasper handle sets (see Step 6).

- i. Fit the handle onto the rose assembly spindle.
- ii. Using the M5 x 0.8 x 14mm socket head cap screw and 4mm hex key provided, secure the handle.

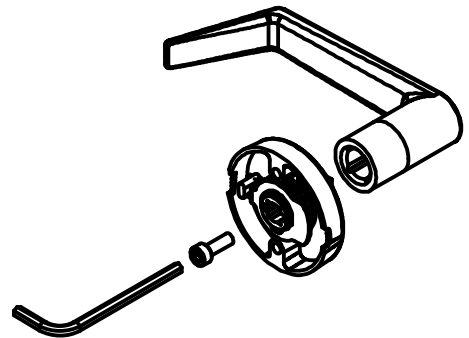

The inside rose scalp cover should not be installed at this point.

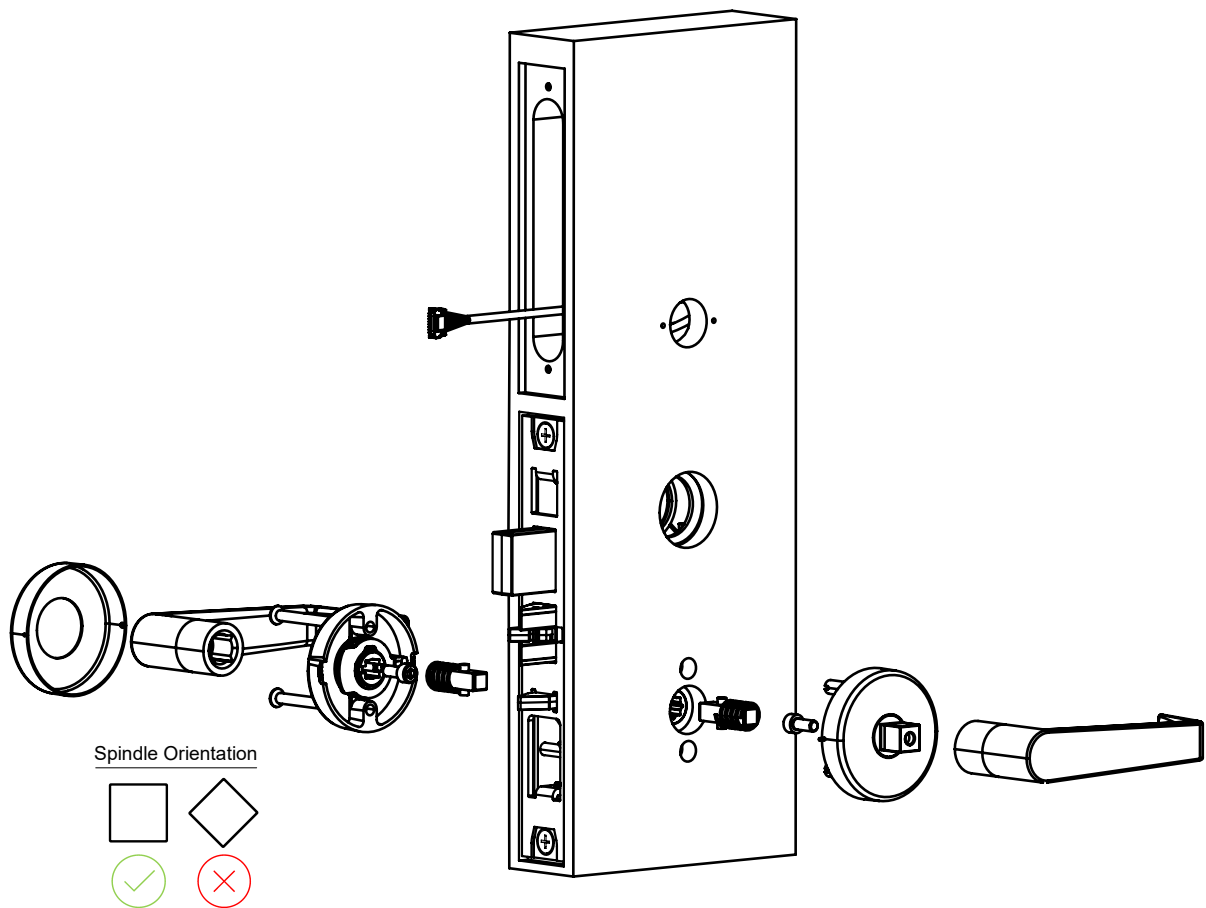

3. Install the spindles and springs on both sides.
  - The springs and the long end of the spindles must be on the handle side (away from the door), as shown above.
  - Ensure that the spindle orientation is correct, as shown above.
4. Install the outside assembly, aligning with the spindle. Confirm spindle engagement by rotating the lever down and verifying that the latch retracts.
5. Install the inside assembly, aligning with the spindle. Confirm spindle engagement.
  - i. Using the #10-24 x 1-½" flat head machine screws provided, secure the inside rose assembly.
 

Do not overtighten the screws, as this can interfere with lock operation.
  - ii. Fit the rose scalp cover onto the inside rose assembly by aligning the dimples with the slots in the rose plate. Secure by rotating clockwise until tight.
6. For Aspiring and Jasper handle sets **only**:
  - i. Slide the lever onto the assembly spindle, ensuring the screw hole is on the underside of the lever.
  - ii. Using the M5 x 0.8 set screw and 2.5mm hex key provided, secure the lever.

## Key Cylinder and Privacy Thumbturn

The following instructions are only required if installing the optional key cylinder and privacy thumbturn.

Ensure that the key cylinder is installed on the outside of the door with the thumbturn on the inside.

1. Insert the key cylinder into the collar and spring, then thread it into the lock body until the cylinder is flush or slightly recessed in the trim collar.
2. Secure the key cylinder following the manufacturer's instructions.
3. Line up the thumbturn vertically so that the mounting holes are accessible, then gently position the thumbturn spindle in the lock body spindle receiver.
4. Secure using the two stainless steel #6 x 1/2" truss head sheet metal screws provided.
5. Test the thumbturn operation of the deadbolt. It should turn smoothly and easily.

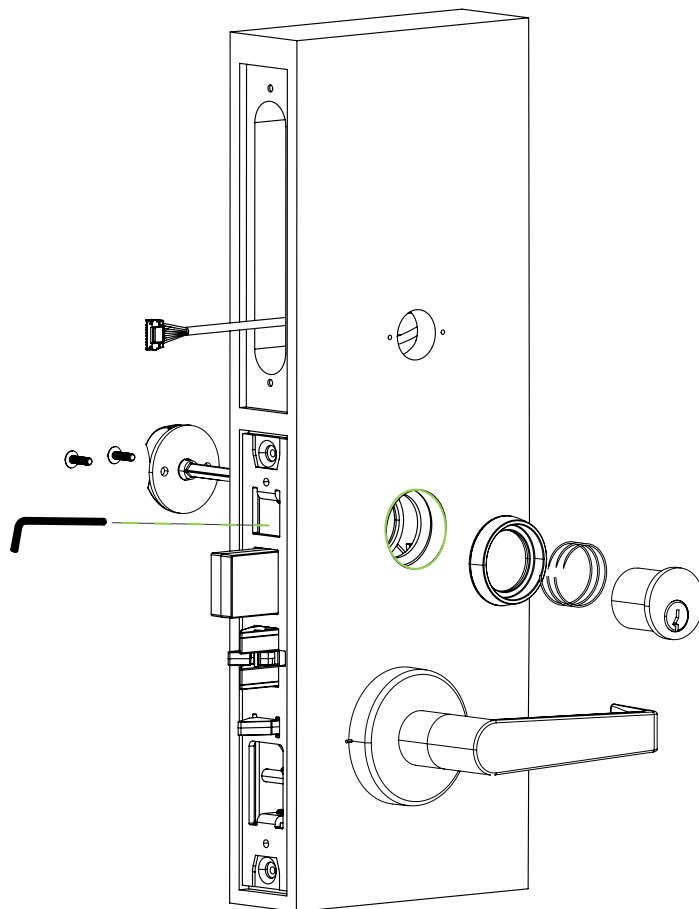

## Installing the Faceplate

1. Using the two #8-32 x 1/4" flat head machine screws provided, install the faceplate.

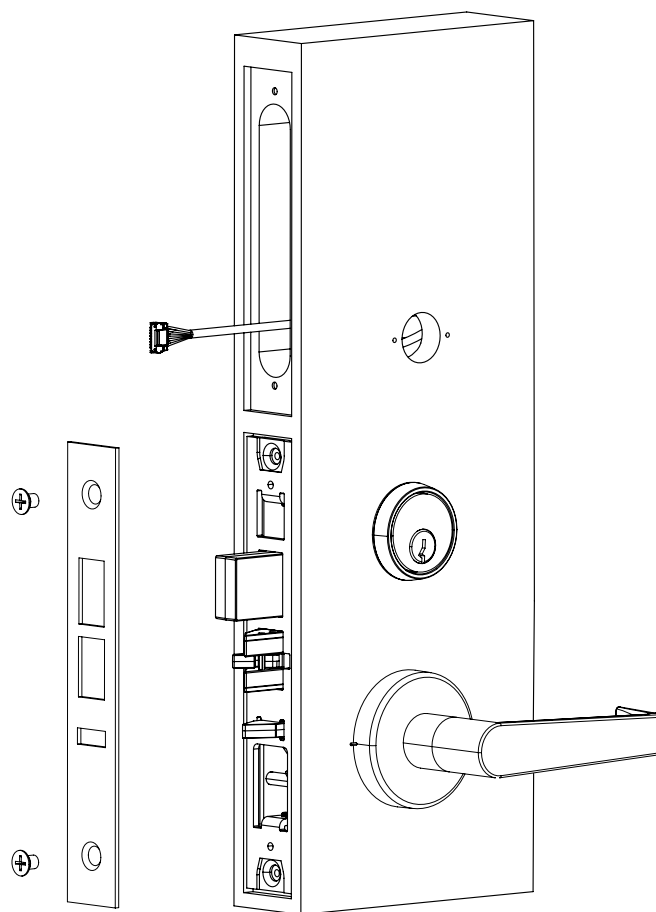

## Installing the Lock Control Cartridge

Take care when unpacking the lock control cartridge to not damage the door position sensor (if included).

### Position the Reader Cable

Before the electronic control cartridge can be installed the attached reader cable needs to be secured from inside the cartridge cavity out through the reader hole using a semirigid wire.

While it may be possible to locate and pull the reader cable through the reader hole after installing the cartridge this will not be possible for some door configurations. Due to the short length of the reader cable and variable door conditions it is recommended to position the reader cable before inserting the cartridge.

1. Attach a semirigid wire to the reader cable connector.
2. Feed the wire in through the cartridge cavity and out through the reader hole so that the reader cable can be pulled through after installing the cartridge.

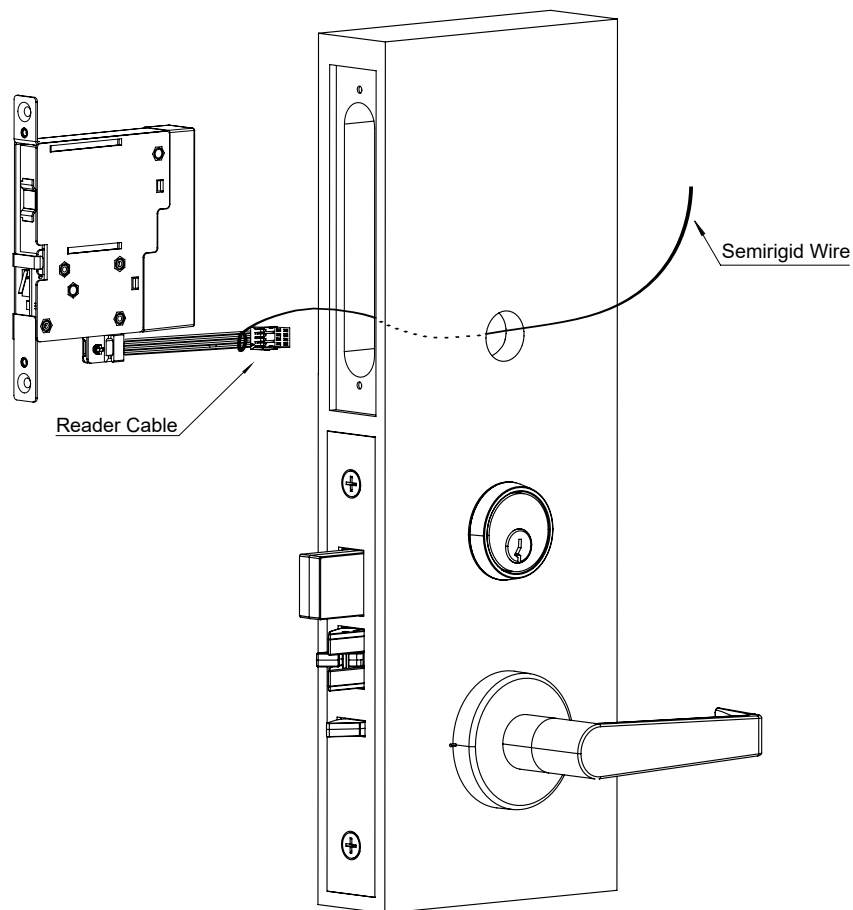

## Connect the Lock Cable

Before installing the cartridge the lock cable needs to be connected.

1. Connect the black lock cable socket plug to the black connector on the bottom of the cartridge.
2. Secure the lock cable to the spare cable clip on the underside of the cartridge.

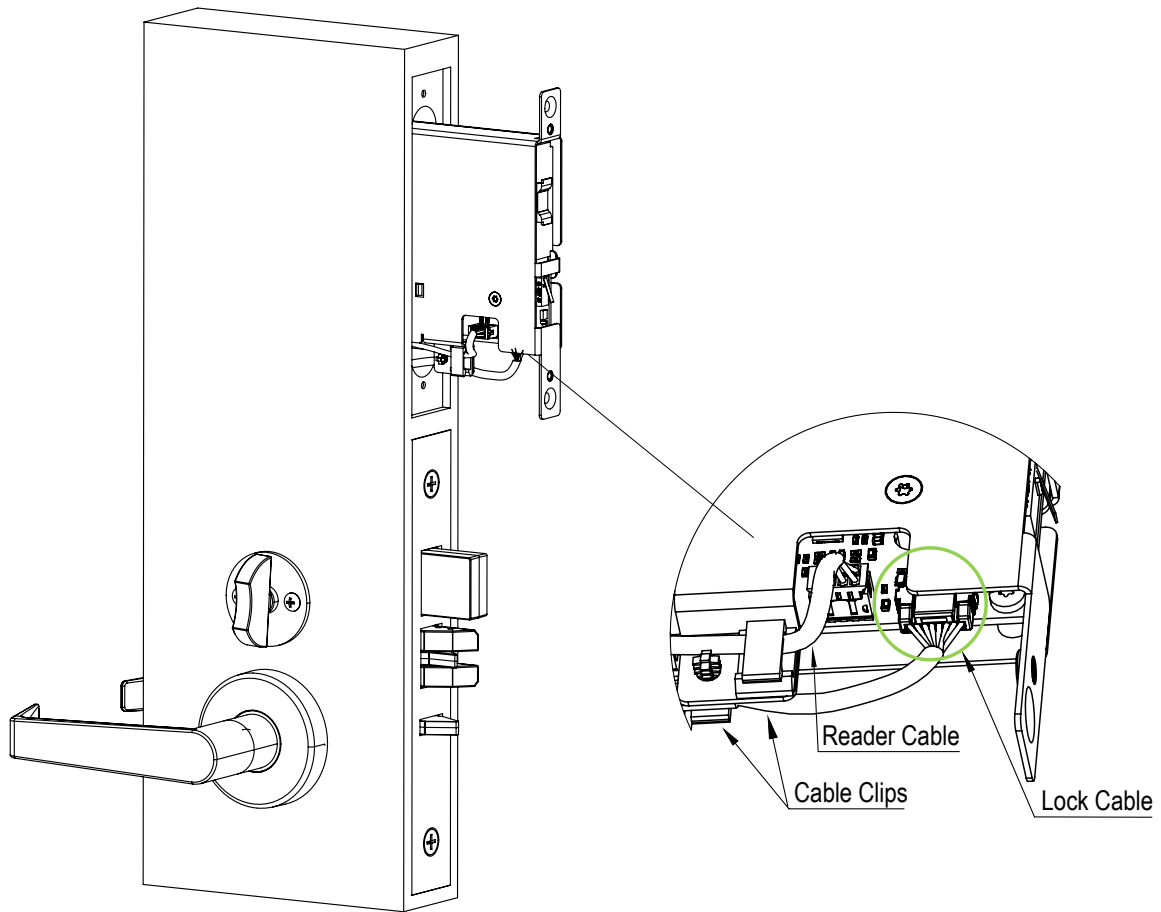



## Secure the Cartridge

1. Insert the lock control cartridge into the cartridge cavity.
2. Pull the reader cable through the reader hole.
3. Using the two G8 x  $\frac{3}{4}$ " flat head screws provided, secure the cartridge in position.

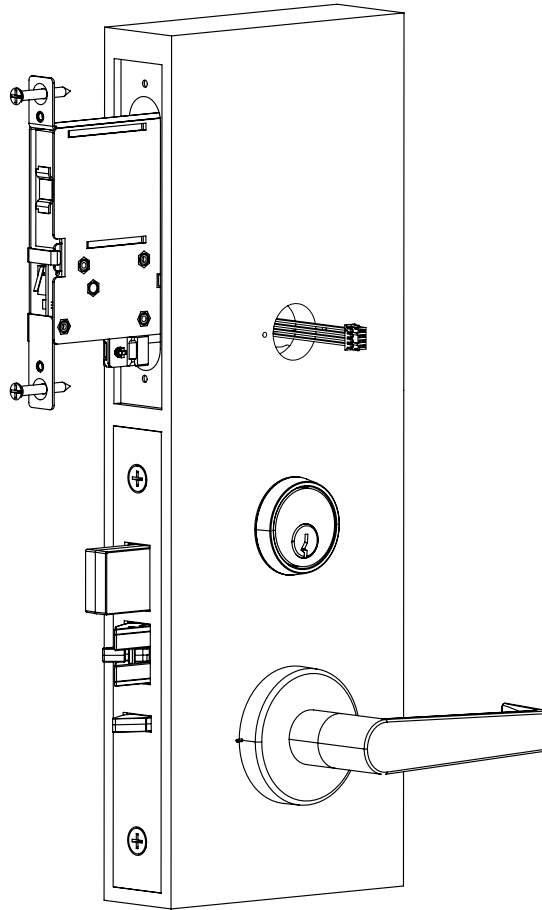

# Installing the Reader

## Connect the Reader

1. Using a small flat screwdriver, release the tab at the bottom of the reader to separate the reader cover from the base.
2. If mounting the reader on a metal surface it is recommended to place the optional ferrite shield (provided) onto the back side of the reader base.

The shield is placed between the reader and the mounting surface to suppress electromagnetic interference caused by the reader's proximity to the metal surface.

3. Connect the reader cable plug to the connector on the back of the reader board.

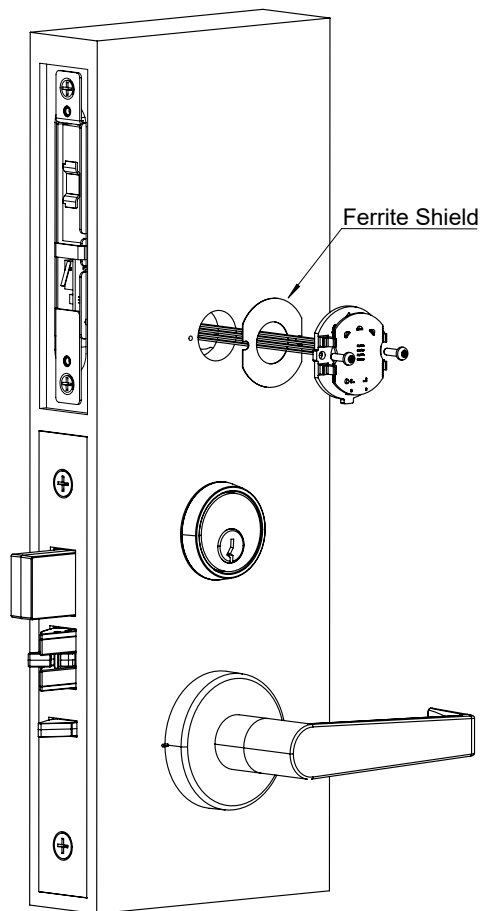

## Attach the Reader

1. Position the reader onto the door, ensuring the USB port is at the bottom.
2. Using the two self-tapping N°4 9.5mm pan head screws provided, fasten the reader in position on the door.

Do not use screws longer than 9.5mm to mount the reader.

3. Position the reader cover over the reader, with the LED strip at the top, and press firmly until the cover clips into position.

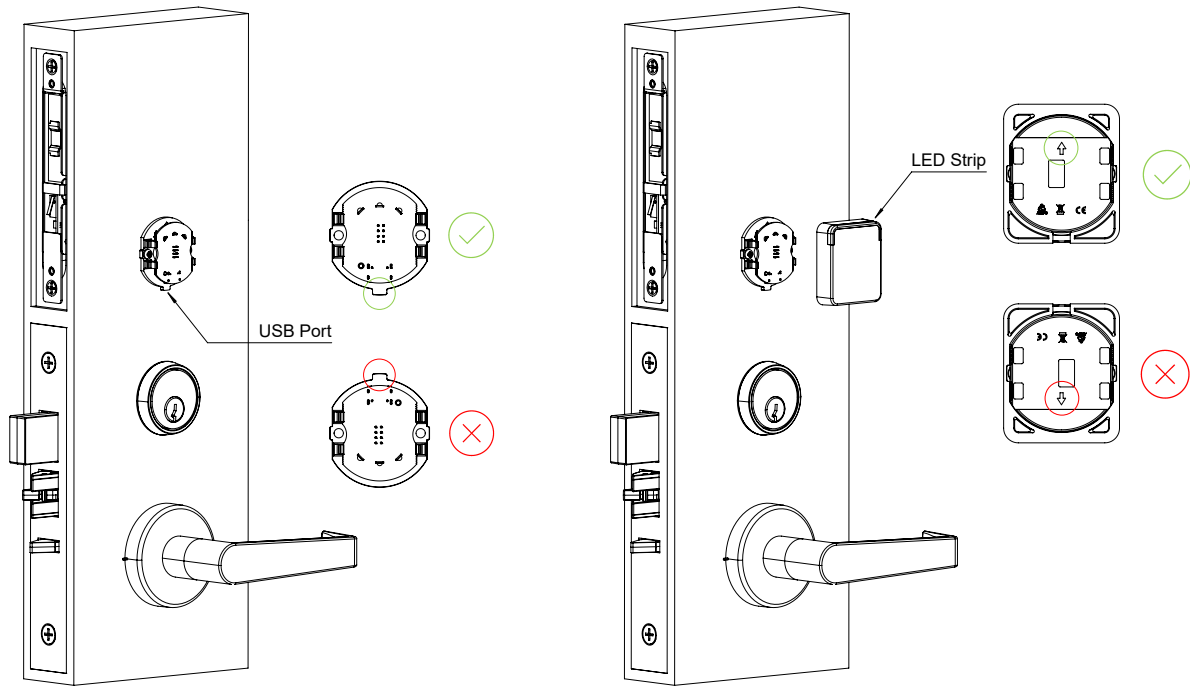

Attach the reader with the USB port at the bottom.

Attach the cover with the LED strip at the top.

Either a rectangular or circular reader cover may be ordered. The process is the same for both covers.

It is not possible to detach the reader board from the base while it is firmly mounted in position. You will need to loosen or remove the mounting screws to allow the flex required to clip/unclip the board (e.g. for maintenance).

## Inserting the Batteries

Rechargeable batteries are not recommended due to reduced charge time and lock operation.

1. Remove the battery holder from the cartridge.
2. Lift the battery cover and insert the 3 x AA batteries provided.
3. Push the battery holder back into the cartridge.
4. Using the two #8-32 x ¼" machine screws provided, install the armor plate.

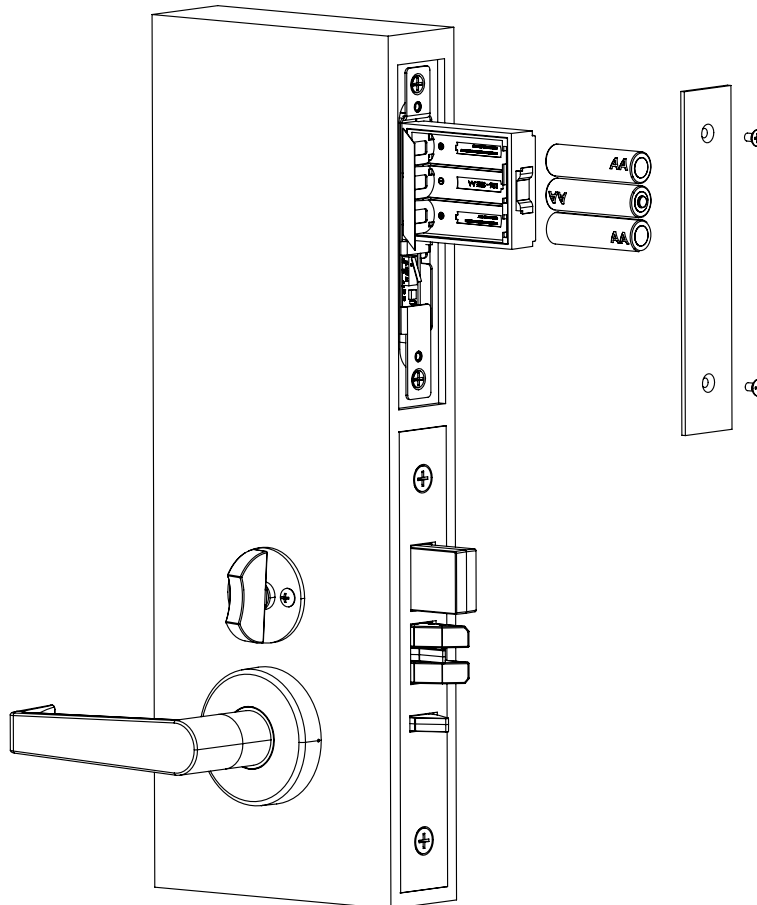

For UL installations (UL 294), UL approved batteries must be used.

For cUL installations (CAN/ULC 60839-11-1), cUL approved batteries must be used.

Approved batteries include Energizer MAX Alkaline.

## Installing the DPS Magnet

A Door Position Sensor (DPS) is preinstalled in the electronic lock control cartridge. If the DPS is required, the accompanying magnet needs to be installed in the door jamb as directly opposite the sensor as practical.

The sensor is positioned 100mm (15/16") from the top of the cartridge armor plate. Note that it is slightly off-center to the reader side, although this difference is negligible in door position operation. The sensor has an operating range of approximately 12mm (15/32") from the armor plate to the magnet before contact is broken.

To install the magnet, drill an 18mm (23/32") diameter hole in the door jamb opposite the sensor.

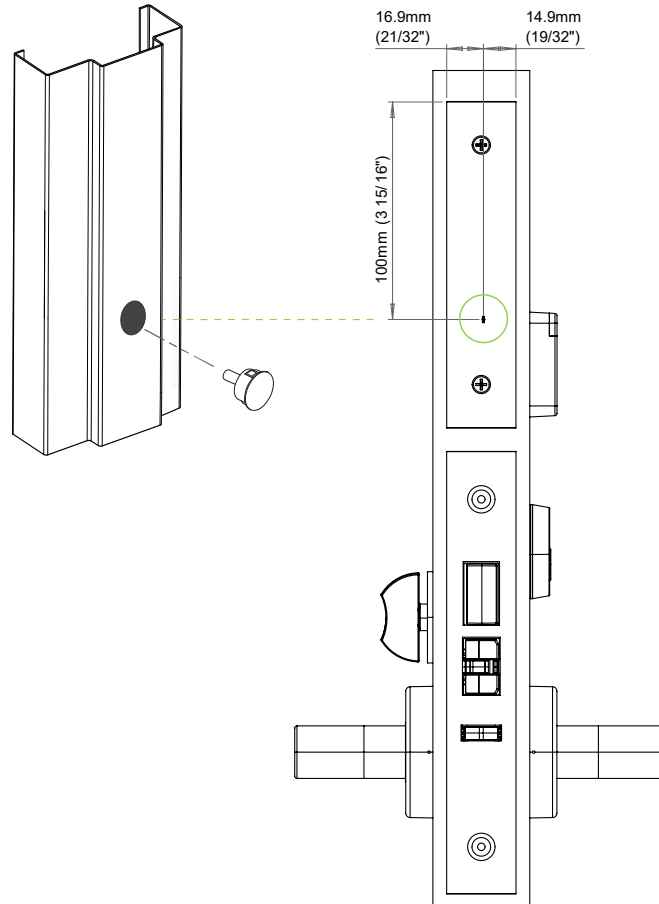

Door position sensor not evaluated by UL/cUL.

# Programming Locks

---

Wireless locks can be programmed for a wide range of functionality to meet your site's requirements.

Offline wireless locks are programmed in the Protege software. You can then use your Protege Config App to download the configuration from an update point and transfer it to the lock via Bluetooth®.

For more information about setting up and programming wireless locks, see the Protege Wireless Lock Configuration Guide, available from the ICT website.

# Operation

Protege wireless locks provide specific audio and visual signals to indicate read response and current status. The following table describes the available LED and beeper response signals.

## Beeper Indicators

- **Short** beeps have a sound and interval duration of **100ms**.
- **Long** beeps have a sound and interval duration of **1 second**.

## Low Battery Indicators

- **Yellow** flash indicates battery voltage less than 3.8V. Batteries need to be replaced within 2-3 **months**.
- **Red** flash indicates battery voltage less than 3.55V. Batteries need to be replaced within 2-3 **weeks**.

Operation	LED Indication	LED Description	Beeper
Access Granted		3 Green flashes (100ms/100ms)	2 short
Access Granted - Battery Low < 3.8V		2 Green flashes (100ms/100ms) 1 Yellow flash (200ms)	2 short
Access Granted - Battery Low < 3.55V		2 Green flashes (100ms/100ms) 1 Red flash (200ms)	2 short
Access Denied		3 Red flashes (100ms/100ms)	1 long
Access Denied - In Privacy Mode		3 Red flashes (200ms/200ms)	1 long
Access Denied - Battery Low < 3.8V		2 Red flashes (100ms/100ms) 1 Yellow flash (200ms)	1 long
Access Denied - Battery Low < 3.55V		2 Red flashes (100ms/100ms) 1 Red flash (200ms)	1 long
Construction Mode - Access Granted		3 Purple flashes (100ms/100ms)	2 short
Construction Mode - Access Granted - Battery Low < 3.8V		2 Purple flashes (100ms/100ms) 1 Yellow flash (200ms)	2 short

Operation	LED Indication	LED Description	Beeper
Construction Mode - Access Granted - Battery Low < 3.55V		2 Purple flashes (100ms/100ms) 1 Red flash (200ms)	2 short
Construction Mode - Access Denied		3 Orange flashes (100ms/100ms)	1 long
Construction Mode - Access Denied - Battery Low < 3.8V		2 Orange flashes (100ms/100ms) 1 Yellow flash (200ms)	1 long
Construction Mode - Access Denied - Battery Low < 3.55V		2 Orange flashes (100ms/100ms) 1 Red flash (200ms)	1 long
Exit Leaves Open Mode - Lock/Unlock Granted		1 Green flash (100ms)	1 short
Exit Leaves Open Mode - Lock/Unlock Denied		3 Red flashes (100ms/100ms)	1 long
Opening Not Allowed - Battery Flat		1 Red flash (20ms)	1 short
Powering Up		Flashing Blue (200ms/200ms) until ready to read (typically 1.5s)	2 short
Powering Up - Battery Low < 3.8V		Flashing Blue (200ms/200ms) until ready to read 1 Yellow flash (200ms)	2 short
Powering Up - Battery Low < 3.55V		Flashing Blue (200ms/200ms) until ready to read 1 Red flash (200ms)	2 short
Factory Reset		5 White flashes (100ms/100ms)	
Blob Version Not Supported		1 White flash (100ms)	
Blob Contains No Configuration		1 White flash (500ms)	



# Maintenance

---

Protege Cartridge Mortise Wireless Locks have an expected battery life of up to two years (40,000 activations), dependent on usage levels and reader configuration. Batteries should be replaced every two years, or earlier if required.

In case of battery failure, remove the reader cover and supply emergency power via the USB-C port at the base of the reader.

Any USB power supply unit can be used to supply emergency power to the lock.

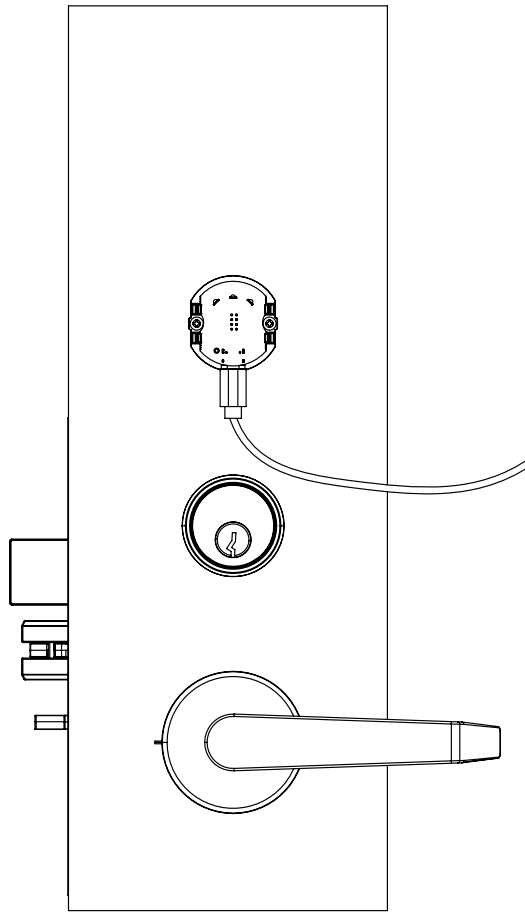

Length of battery life not evaluated by UL.

# Mechanical Layout

Optional key cylinder is not supplied.

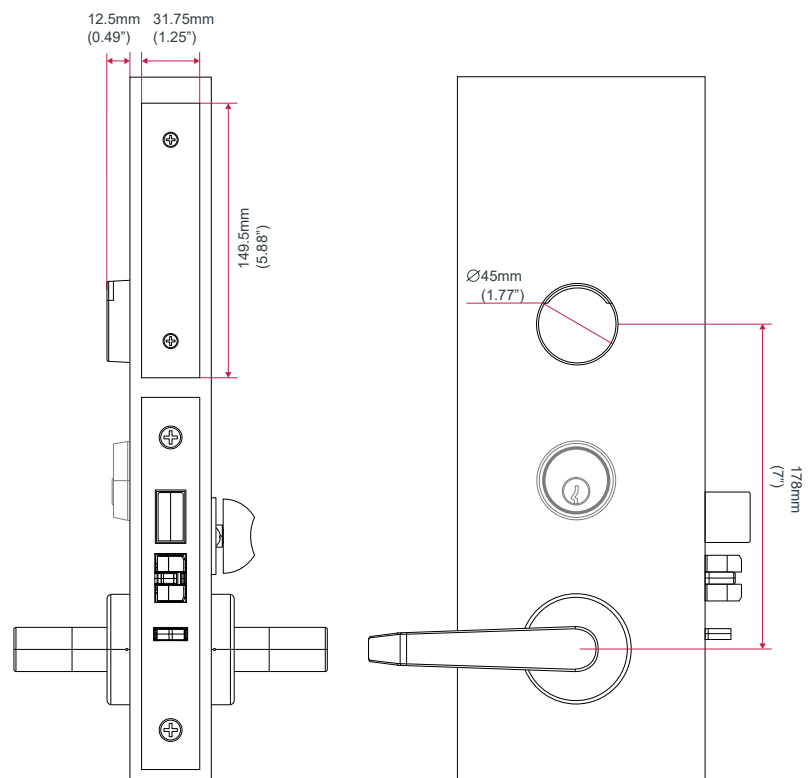
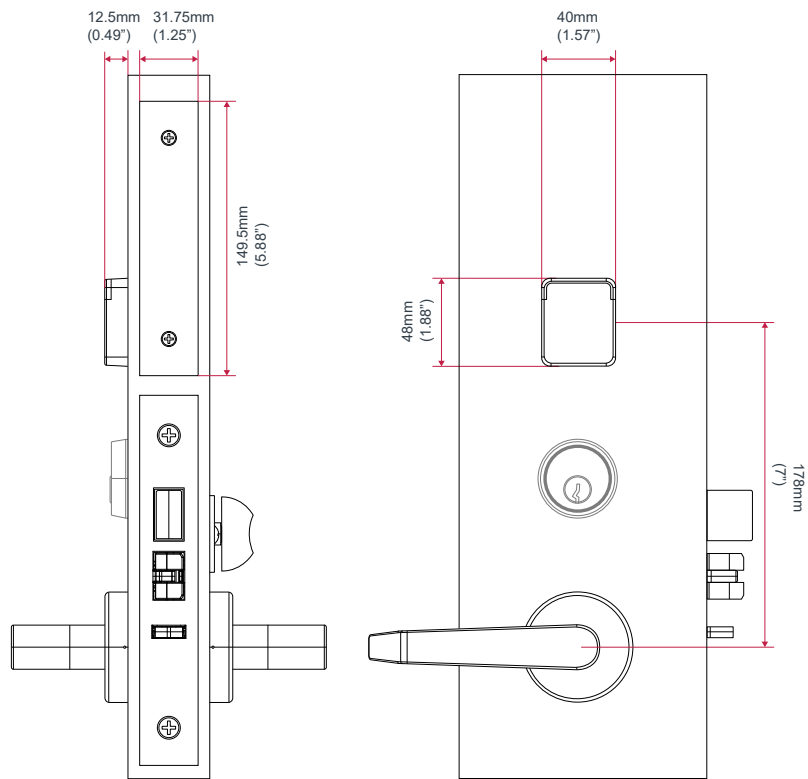

# Door Template

This template is included for information only and may not be to scale. For a version of this template that can be printed to scale, go to [www.ict.co/cartridge-mortise-template](http://www.ict.co/cartridge-mortise-template)

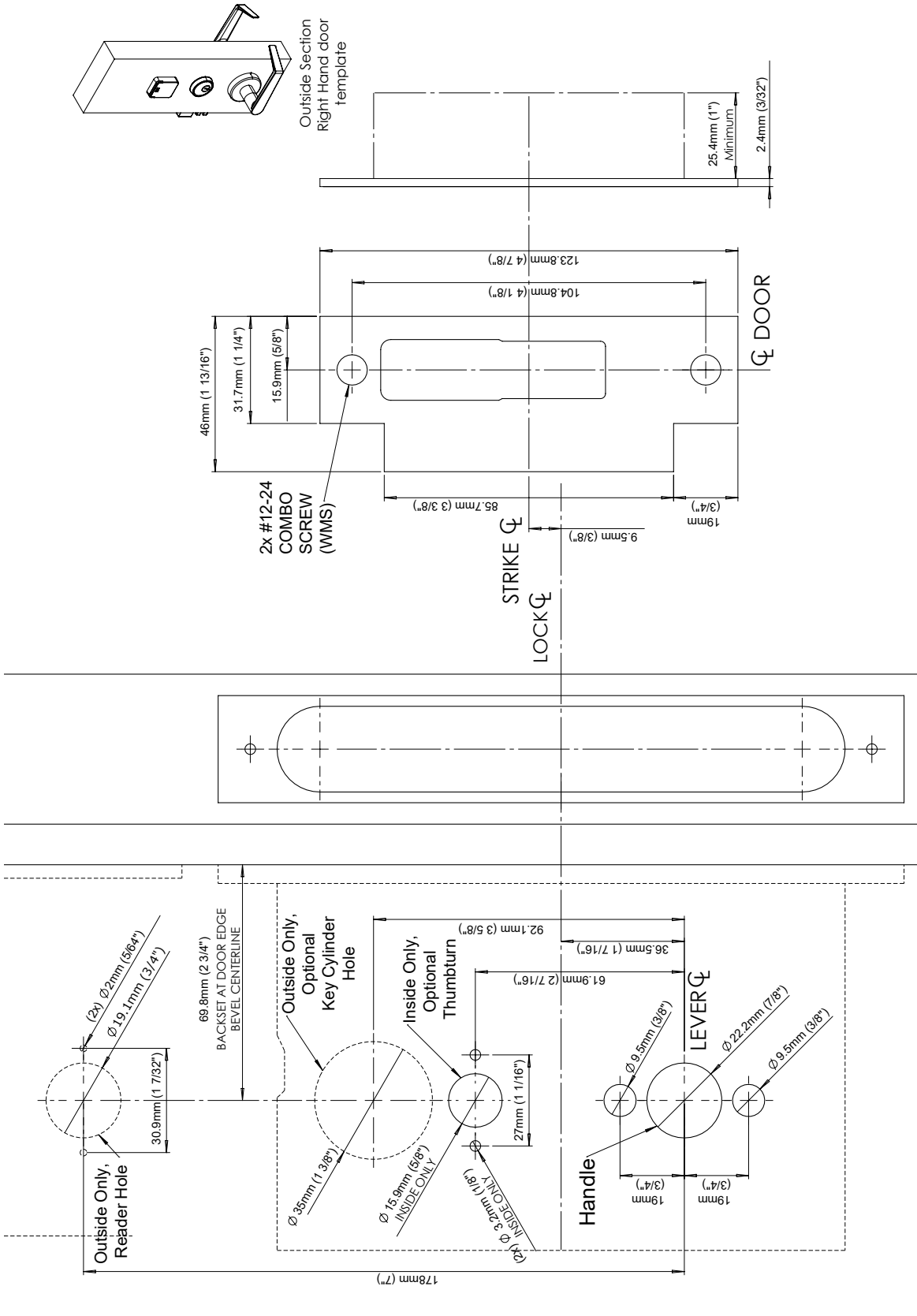

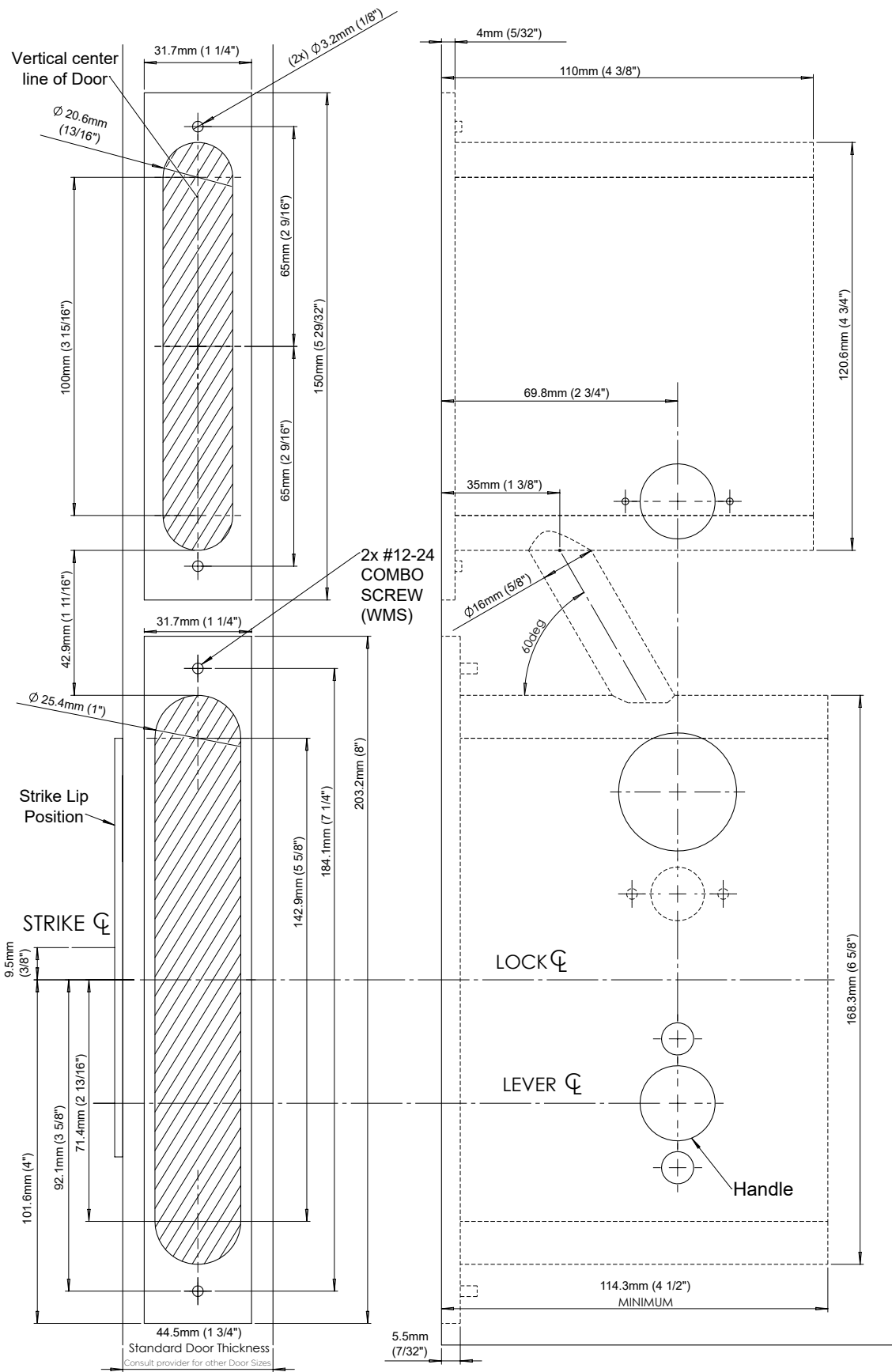

# Technical Specifications

The following specifications are important and vital to the correct operation of this product. Failure to adhere to the specifications will result in any warranty or guarantee that was provided becoming null and void.

Ordering Information	
Order Codes	See Hardware Options
Power Supply	
Battery	Alkaline AA 1.5V (x3) UL/cUL Energizer MAX Alkaline
Expected Battery Life	Up to 2 years (40,000 activation cycles) Length of battery life not evaluated by UL.
Emergency Power Supply	USB-C connection allows power supply for emergency opening
Operating Voltage	Rated 4.5VDC Operating range 3.83 - 4.95VDC
Operating Current	370mA (Peak, Door Activation)
Average Operating Current	82µA (Standby Mode)
Memory	
Event Memory Storage	40,000 log entries
Communications	
Frequency	13.56 MHz ISO/IEC 14443 Type A
Card Read Range	20mm (0.79") (Typical)
Tag Read Range	15mm (0.59") (Typical)
Bluetooth® Wireless Technology	
Bluetooth® Read Range	Proximity mode: up to 0.5m (1.6ft) configurable Action unlock (shake): up to 5m (16.4ft) configurable
Bluetooth® Electronic Credential Transmission Technology	Bluetooth® version 5.2 compliant Proprietary data exchange protocol. AES-128 encrypted Credentials can be distinguished by unique site code and card number
Bluetooth® Wireless Device	Protege Mobile 1.0.x
Lock Specification	
Lock Type	Grade 1 mortise lock
Casing	12 gauge heavy duty dichromated alloy steel
Faceplate	Stainless steel. Beveled. H x W 203.2 x 31.75mm (8 x 1.25")
Strike Plate	Stainless steel. Non-handed. Curved lip
Latchbolt	Stainless steel. Anti-friction. 19mm (0.75") throw
Deadbolt	Stainless steel. 25.4mm (1") throw
Handle Rotation	35 degrees

Door Thickness	44.45 to 50.8mm (1.75 to 2") standard. Larger thickness by special order	
<b>Control Hardware Dimensions</b>		
Reader Cover	Circular (OD x D)	Ø 45 x 12.5mm (Ø 1.77 x 0.49")
	Rectangular (H x W x D)	48 x 40 x 12.5mm (1.89 x 1.57 x 0.74")
Control Cartridge (H x W x D)	95 x 42.8 x 18.9mm (3.74 x 1.69 x 0.49")	
Armor Plate (H x W)	150 x 31.7mm (5.9 x 1.25")	
<b>Operating Conditions</b>		
Operating Temperature	UL/cUL 0° to 49°C (32° to 120°F)	
Storage Temperature	-10° to 85°C (14° to 185°F)	
Humidity	0%-93% non-condensing, indoor use only (relative humidity)	
Mean Time Between Failures (MTBF)	520,834 hours (calculated using RDF 2000 (UTE C 80-810) Standard)	

The **Bluetooth**® word mark and logos are registered trademarks owned by Bluetooth SIG, Inc. and any use of such marks by Integrated Control Technology is under license. Other trademarks and trade names are those of their respective owners.

Integrated Control Technology continually strives to increase the performance of its products. As a result these specifications may change without notice. We recommend consulting our website ([www.ict.co](http://www.ict.co)) for the latest documentation and product information.

# UL and cUL Installation Requirements

---

Only UL / cUL listed compatible products are intended to be connected to a UL / cUL listed control system.

## CAN/ULC-60839-11-1

- This card reader is CAN/ULC-60839-11-1 Listed for Class I applications only.
- Exit devices and wiring must be installed within the protected area.
- The card reader must be connected with shielded, grounded cable.
- Fail secure locking mechanism shall only be installed where allowed by the local authority having jurisdiction (AHJ) and shall not impair the operation of panic hardware and emergency egress.
- **Security Grade:** 1
- **Environmental:** Indoor, dry
- **Lock Firmware Version:** 1.0.XXXX

## UL 294

- This card reader is UL 294 Listed for Class 1 applications only.
- Exit devices and wiring must be installed within the protected area.
- The card reader must be connected with shielded, grounded cable.
- Fail secure locking mechanism shall only be installed where allowed by the local authority having jurisdiction (AHJ) and shall not impair the operation of panic hardware and emergency egress.
- A means of verification shall be employed by the user to enable access to the wireless electronic device such as a PIN or biometric feature, which subsequently provides access to the credential application software present on the wireless electronic device.
- The access control system shall have the means to distinguish between the type of credential used via code or description (e.g. authentication/digital signature keys received from a physical card vs. authentication/digital signature keys received from a wireless electronic credential.)
- **Lock Firmware Version:** 1.00.XXXX

## Performance Levels

- **Line Security:** Level I
- **Destructive Attack:** Level I
- **Endurance:** Level IV
- **Standby Power:** Level I

## UL 1034

- **Static Strength:** 1000 pounds-force (4448N)
- **Dynamic Strength:** 50 foot-pound-force (68J)
- **Endurance:** 100,000 cycles

**Note:** The ICT Protege Config App is used for onsite installation, troubleshooting and programming.

## Flammability Standards

- This lock has been tested and found to comply with UL 10C and CAN/ULC-S104.
- This lock is rated for UL 10C for up to 3 hours when installed in a steel fire rated door.
- This lock is rated for UL 10C for up to 20 minutes when installed in a wooden fire rated door.
- This lock must be installed with approved alkaline batteries for compliance with UL/cUL. Lithium batteries are **not permitted**.



# FCC Compliance Statements

---

## FCC PART 15, WARNINGS: INFORMATION TO USER

This equipment has been tested and found to comply with the limits for a Class B digital device, pursuant to part 15 of the FCC Rules. These limits are designed to provide reasonable protection against harmful interference in a residential installation. This equipment generates, uses and can radiate radio frequency energy and, if not installed and used in accordance with the instructions, may cause harmful interference to radio communications. However, there is no guarantee that interference will not occur in a particular installation. If this equipment does cause harmful interference to radio or television reception, which can be determined by turning the equipment off and on, the user is encouraged to try to correct the interference by one or more of the following measures:

- Reorient or relocate the receiving antenna.
- Increase the separation between the equipment and receiver.
- Connect the equipment into an outlet on a circuit different from that to which the receiver is connected.
- Consult the dealer or an experienced radio/TV technician for help.

Changes or modifications not authorized by the party responsible for compliance could void the user's authority to operate this product.

This device complies with Part 15 of the FCC rules.

Operation is subject to the following two conditions:

- This device may not cause harmful interference.
- This device must accept any interference received, including interference that may cause undesired operation.

NOTE: THE GRANTEE IS NOT RESPONSIBLE FOR ANY CHANGES OR MODIFICATIONS NOT EXPRESSLY APPROVED BY THE PARTY RESPONSIBLE FOR COMPLIANCE. SUCH MODIFICATIONS COULD VOID THE USER'S AUTHORITY TO OPERATE THE EQUIPMENT.

# Industry Canada Statement

---

This class A digital apparatus complies with Canadian ICES-003.

Cet appareil numérique de la classe A est conforme à la norme NMB-003 du Canada.

CAN ICES-3 (A)/NMB-3(A)

# Disclaimer and Warranty

---

**Disclaimer:** Whilst every effort has been made to ensure accuracy in the representation of this product, neither Integrated Control Technology Ltd nor its employees shall be liable under any circumstances to any party in respect of decisions or actions they may make as a result of using this information. In accordance with the ICT policy of enhanced development, design and specifications are subject to change without notice.

For warranty information, see our [Standard Product Warranty](#).

Designers & manufacturers of integrated electronic access control, security and automation products.  
Designed & manufactured by Integrated Control Technology Ltd.  
Copyright © Integrated Control Technology Limited 2003-2024. All rights reserved.

**Disclaimer:** Whilst every effort has been made to ensure accuracy in the representation of this product, neither Integrated Control Technology Ltd nor its employees shall be liable under any circumstances to any party in respect of decisions or actions they may make as a result of using this information. In accordance with the ICT policy of enhanced development, design and specifications are subject to change without notice.