



PRT-F2F8-DIN

Protege Half DIN Rail 8 Port F/2F Reader Expander

Installation Manual



The specifications and descriptions of products and services contained in this document were correct at the time of printing. Integrated Control Technology Limited reserves the right to change specifications or withdraw products without notice. No part of this document may be reproduced, photocopied, or transmitted in any form or by any means (electronic or mechanical), for any purpose, without the express written permission of Integrated Control Technology Limited. Designed and manufactured by Integrated Control Technology Limited, Protege® and the Protege® Logo are registered trademarks of Integrated Control Technology Limited. All other brand or product names are trademarks or registered trademarks of their respective holders.

Copyright © Integrated Control Technology Limited 2003-2026. All rights reserved.

Last Published: 08-Jan-26 12:49 PM

Contents

Introduction	4
Installation Requirements	5
Dual Stack Connectors	5
Grounding Requirements	6
Safety Grounding	6
Earth Ground Connection	6
Mounting	8
Removal	8
DC Power & Encrypted Module Network	9
End-of-Line (EOL) Resistors	9
Door Access Control	10
Reader Connection	10
Door Lock Connection	11
Trouble Inputs	12
Door Trouble Inputs	12
Outputs	13
Address Configuration	14
LED Indicators	15
Status Indicator	15
Fault Indicator	15
Power Indicator	15
Error Code Indication	16
Error Code Display	16
Mechanical Diagram	17
Mechanical Layout	18
Technical Specifications	19
New Zealand and Australia	20
European Standards	21
UK Conformity Assessment Mark	23
FCC Compliance Statements	24
Industry Canada Statement	25
Disclaimer and Warranty	26

Introduction

The Protege Half DIN Rail 8 Port F/2F Reader Expander is an 8-port F/2F and supervised F/2F reader expander module designed as a replacement for legacy Casi-Rusco Picture Perfect, Secure Perfect and other similar proprietary F/2F systems.

Flexible module network architecture allows large numbers of modules to be connected to the RS-485 module network. Up to 250 modules can be connected to the Protege system in any combination to the network, over a distance of up to 900M (3000ft). Further span can be achieved with the use of a network repeater module.

The current features of the reader expander include:

- 8 individual card reader ports on each F/2F reader expander module
- Half DIN, dual stack design for easy mounting into existing installation enclosures
- Secure encrypted RS-485 module communications
- 8 outputs (lock control outputs)
- Remote upgradeable firmware

Installation Requirements

This equipment is to be installed in accordance with:

- The product installation instructions
- The Local Authority Having Jurisdiction (AHJ)

Dual Stack Connectors

This half DIN rail product employs an economical dual stack design which accommodates a double layer PCB with two rows of connectors. This requires the use of a specific connector configuration in which the design of the upper connectors is slightly different to the lower connectors. Pin positions on one row are incompatible with the connections on the other, and swapping upper and lower connectors may damage the connectors and the PCB.

Please check carefully before inserting connectors as incorrect placement can cause damage to the PCB.

Grounding Requirements

An effectively grounded product is one that is intentionally connected to earth ground through a ground connection or connections of sufficiently low impedance and having sufficient current-carrying capacity to prevent elevated voltages that may result in undue hazard to connected equipment or to persons.

Grounding of the Protege system is done for three basic reasons:

1. Safety
2. Component protection
3. Noise reduction

Safety Grounding

The object of safety grounding is to ensure that all metalwork is at the same ground (or earth) potential. Impedance between the Protege system and the building scheme ground must conform to the requirements of national and local industrial safety regulations or electrical codes. These will vary based on country, type of distribution system and other factors. The integrity of all ground connections should be checked periodically.

General safety dictates that all metal parts are connected to earth with separate copper wire or wires of the appropriate gauge.

Warning: All cabinet internal covers and lids/doors must be connected to the cabinet's main ground point for electrical safety and static discharge protection.

Earth Ground Connection

The DIN rail enclosure and the DIN rail modules must be grounded to a suitable single-point earth ground connection in the installation. A minimum 14AWG solid copper wire (or thicker, in accordance with local authorities) shall be used from the Protege system's earth connection points.

The DIN rail enclosure includes an earth ground single-point link connection via the metallic enclosure. This single-point link is the Protege system's earth ground. All modules that have earth ground connections and that are installed in the same enclosure shall be connected to this single point. A single-point earth ground connection avoids the creation of ground loops in the system and provides a single reference point to earth ground.

DIN Rail Ground Connections (one or more cabinets installed in the same room)

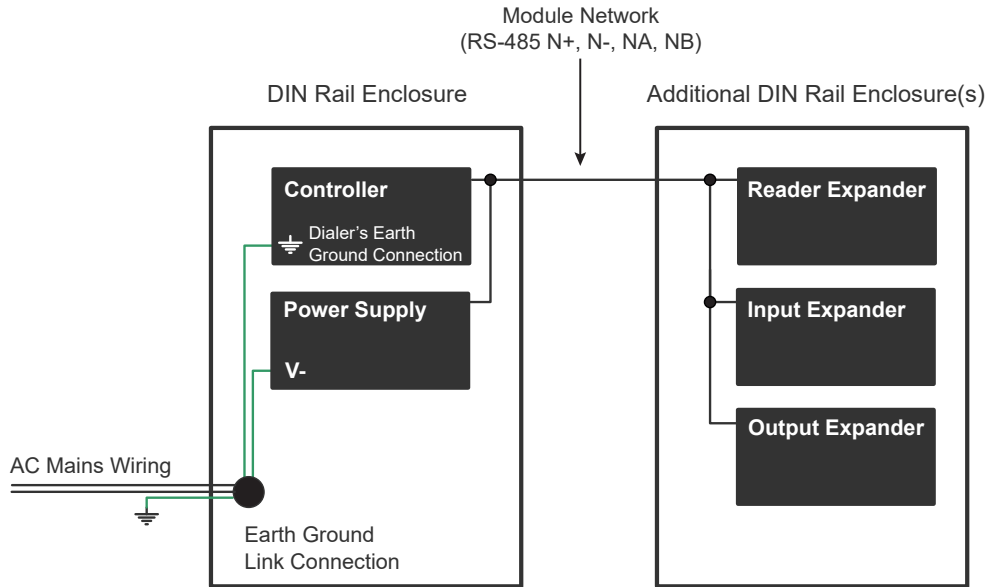

DIN Rail Ground Connections (multiple cabinets in different rooms, sectors, or buildings)

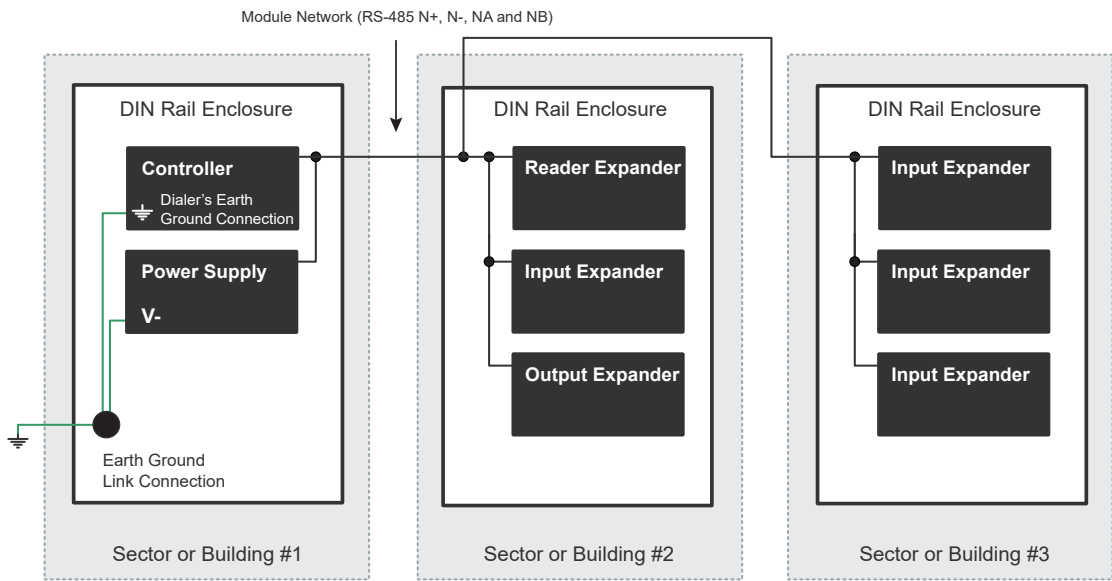

The Dialer's Earth Ground Connection applies to modem model controllers only.

Note that the DIN rail enclosure earth terminal is connected to the power supply V- terminal.

There must be only **one** single earth grounding point per system.

Mounting

Protege half DIN rail modules are designed to mount on standard DIN rail, either in dedicated DIN cabinets or on generic DIN rail mounting strip.

They can also be hung from the top mount screw and permanently fastened using the hole in the attachment clip.

Location

Protege DIN rail modules must be installed indoors, within the protected area. Modules must be protected by a secure cabinet with tamper detection.

We recommend installing the cabinet in a location that provides easy access for wiring. Suitable locations include electrical rooms, communication equipment rooms and accessible areas of the ceiling. Ensure that there is adequate clearance around each device and that air flow to the vents is not restricted.

Protege DIN rail modules must not be installed outdoors. Ensure that the room does not exceed or fall below the operating temperature or humidity ranges listed in the [Technical Specifications](#) for each module. Do not mount cabinets on the exterior of a vault, safe or stockroom.

Mounting a DIN Rail Module

To mount a module onto DIN rail:

1. Position the module with the labeling in the correct orientation.
2. Hook the mounting tabs (opposite the tab clip) under the edge of the DIN rail.
3. Push the DIN rail module against the mount until the tab clips over the rail.

Removal

To remove the DIN rail module from the DIN rail mount:

1. Insert a flat-blade screwdriver into the slot in the module tab clip.
2. Lever the tab outwards and rotate the unit off the DIN rail mount.

DC Power & Encrypted Module Network

The expander incorporates encrypted RS-485 communications technology, and both module and network power are supplied by the N+ and N- terminals.

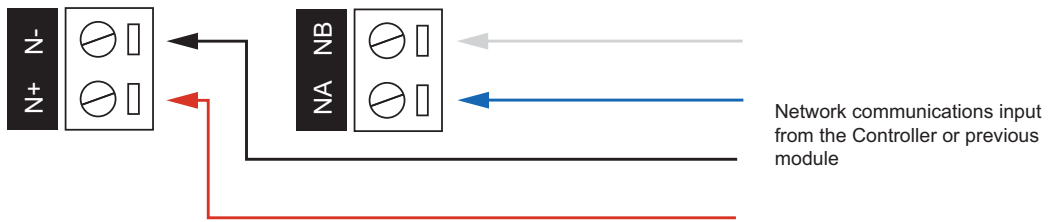

Connection of the communications and DC supply should be performed according to the diagram shown above. It is important that the N+ network communications power be 12VDC supplied from an independent battery backed power supply unit capable of supplying the required voltage to all devices on the RS-485 network.

Warning: The 12V N+ and N- communication input must be supplied from only **one** point. Connections from more than one 12V supply may cause failure or damage to the unit or the device supplying network power.

End-of-Line (EOL) Resistors

End-of-line resistors prevent signal reflections at the ends of the RS-485 network bus, improving signal strength and reducing data corruption.

You must insert a **120Ω resistor** between the NA and NB terminals of the **first** and **last** modules on the RS-485 network. These are the modules physically located at the ends of the RS-485 network cabling.

First Module on RS-485 Network

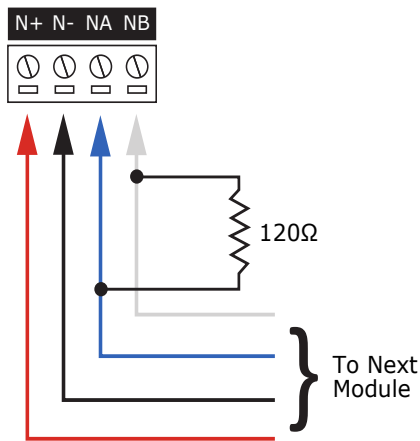

Last Module on RS-485 Network

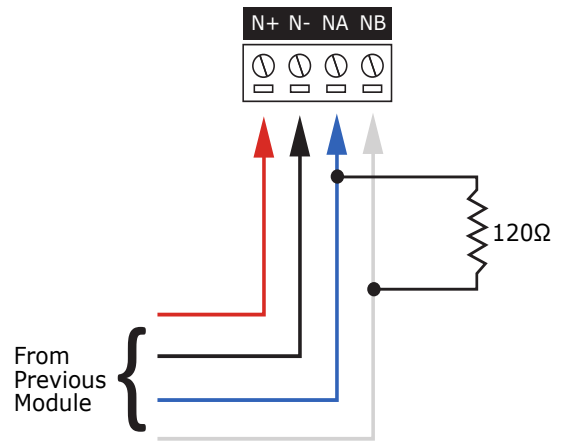

Door Access Control

The F/2F reader expander allows the control of eight F/2F or combined keypad and F/2F card readers used for access control.

Reader Connection

The F/2F reader expander allows the connection of eight data card reading devices with the ability to control door locks (entry or exit only).

Data Card Reader Interface:

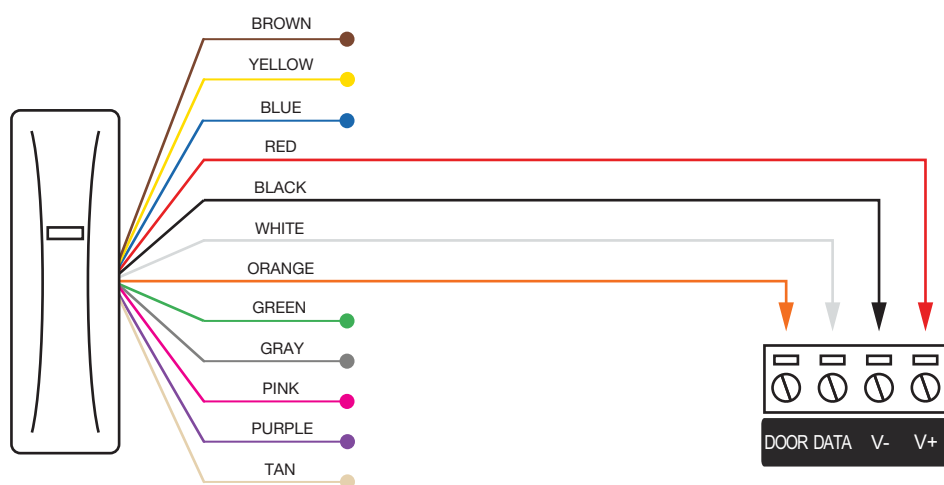

- Use a shielded cable to connect the card reader to the module port.
- Frame ground the shield to the metallic enclosure at one end only.
- Do not connect the cable shield to an AUX-, 0V or V- connection on the module.
- Do not connect the cable shield to any shield used for isolated communication.
- The reader pigtail shield and cable shield wires should be joined at the reader pigtail splice.
- Do not terminate the reader shield wire inside the reader.

Always refer to the card reader manufacturer for detailed installation guidelines.

Up to 400m of Cat 6 UTP 24AWG cable, with paralleled pairs, can be used to connect the card reader and the F/2F reader expander.

Door Lock Connection

The F/2F reader expander provides eight outputs that can be used for control of electric door lock circuits. Control of a door lock circuit relay is achieved by connection between the +12VDC (V+) and the DO (DOOR) terminals on a port of the reader expander.

Door Lock Outputs:

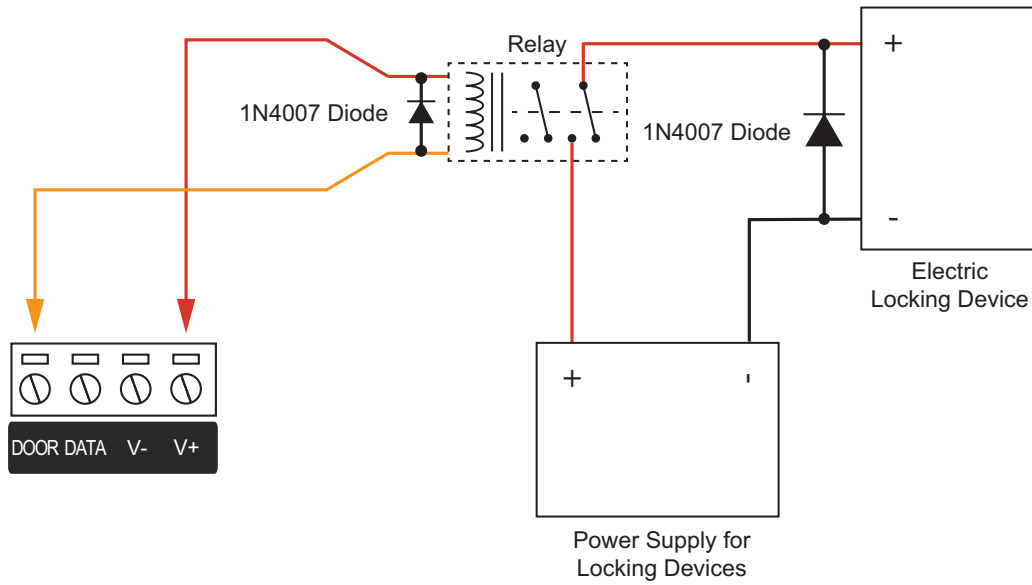

Trouble Inputs

Each reader expander can monitor up to 13 trouble inputs used to report trouble conditions such as module communications problems.

Trouble inputs are used to monitor the module status and in most cases are not physically connected to an external input.

The following table details the trouble inputs that are configured in the system and the trouble groups that they are associated with.

Input Number	Description	Default Trouble Group	Default Trouble Group Option
RDxxx:01	Reader 1 Tamper / Missing	System	Module Tamper
RDxxx:02	Reader 2 Tamper / Missing	System	Module Tamper
RDxxx:03	Reader 3 Tamper / Missing	System	Module Tamper
RDxxx:04	Reader 4 Tamper / Missing	System	Module Tamper
RDxxx:05	Reader 5 Tamper / Missing	System	Module Tamper
RDxxx:06	Reader 6 Tamper / Missing	System	Module Tamper
RDxxx:07	Reader 7 Tamper / Missing	System	Module Tamper
RDxxx:08	Reader 8 Tamper / Missing	System	Module Tamper
RDxxx:09	Auxillary Fuse / Supply Fault Port 1 / 2	General	Power
RDxxx:10	Auxillary Fuse / Supply Fault Port 3 / 4	General	Power
RDxxx:11	Auxillary Fuse / Supply Fault Port 5 / 6	General	Power
RDxxx:12	Auxillary Fuse / Supply Fault Port 7 / 8	General	Power
RDxxx:13-15	Reserved	None	None
RDxxx:16	Module Offline	System	Module Offline

Replace 'xxx' with the address of the module that you are programming.

Door Trouble Inputs

In addition to the trouble inputs of the module itself, the reader expander can also monitor trouble inputs associated with connected doors. These are used for monitoring and reporting door troubles such as door forced and duress conditions.

Input Number	Description	Default Trouble Group	Default Trouble Group Option
Door xxx 01	Door Forced	Access	Forced Door
Door xxx 02	Door Left Open	Access	Left Open
Door xxx 08	Door Duress	None	None

'xxx' refers to the **Name** of the door in the Protege system.

Outputs

The reader expander has 8 programmable outputs. These outputs are used for activation of door lock relay circuits (200mA max sink, 24VDC max).

Address Configuration

Protege modules are set to address 254 at the factory. This is above the address range that the controller supports, so the module will not come online immediately when you connect it to the module network.

To bring the module online, you must set the module address to a valid unused address. See the Protege system controller configuration guide for instructions on how to program the address.

You will need the module's serial number to set the address. You can find the serial number on the identification sticker on the product.

LED Indicators

Protege DIN rail modules feature comprehensive diagnostic indicators that can aid the installer in diagnosing faults and conditions. In some cases an indicator may have multiple meanings depending on the status indicator display at the time.

Status Indicator

The status indicator displays the module status.

State	Description
Fast flash (green)	Module attempting registration with controller
Slow flash (green)	Module successfully registered with controller
Flashing (red)	Module communications activity

When the fault and status indicators are flashing alternately, the module is in identification mode, enabling the installer to easily identify the module in question. Upon either a module update or the identification time period expiring, the module will return to normal operation.

Fault Indicator

The fault indicator is lit any time the module is operating in non-standard mode. If the fault indicator is flashing, the module requires a firmware update or is in firmware update mode. When the fault indicator is on, the status indicator will flash an error code.

State	Description
Continuous slow flash (red)	Module is in boot mode awaiting firmware update
Constantly on (red)	Module is in error state and will flash an error code with the status indicator

Power Indicator

The power indicator is lit whenever the correct module input voltage is applied across the N+ and N- terminals.

State	Description
Constantly on (green)	Correct module input voltage applied
Constantly off	Incorrect module input voltage applied

Error Code Indication

When the module attempts to register or communicate with the system controller a registration error can be generated indicating that it was not successful.

Error Code Display

The following table is only valid if the **fault** indicator is constantly on and the **status** indicator is flashing red.

If the fault indicator is flashing the module requires a firmware update or is currently in firmware update mode.

The status indicator will flash red with the error code number. The error code number is shown with a 250ms on and off period (duty cycle) with a delay of 1.5 seconds between each display cycle.

Flash	Error Description
1	Unknown Error Code The error code returned by the system controller could not be understood by the module.
2	Firmware Version The firmware version on the module is not compatible with the system controller. To clear this error, update the module using the module update feature in the controller's web interface.
3	Address Too High The module address is above the maximum number available on the system controller. To clear this error change the address to one within the range set on the system controller, restart the module by disconnecting the power.
4	Address In Use The address is already in use by another module. To clear this error set the address to one that is not currently occupied. Use the view network status command to list the attached devices, or the network update command to refresh the registered device list.
5	Controller Secured Registration Not Allowed The controller is not accepting any module registrations. To allow module registrations use the network secure command to change the setting to not secured.
6	Serial Number Fault The serial number in the device is not valid. Return the unit to the distributor for replacement.
7	Locked Device The module or system controller is a locked device and cannot communicate on the network. Return the unit to the distributor for replacement.

Mechanical Diagram

The diagram below outlines the essential details needed to help ensure the correct installation of the reader expander.

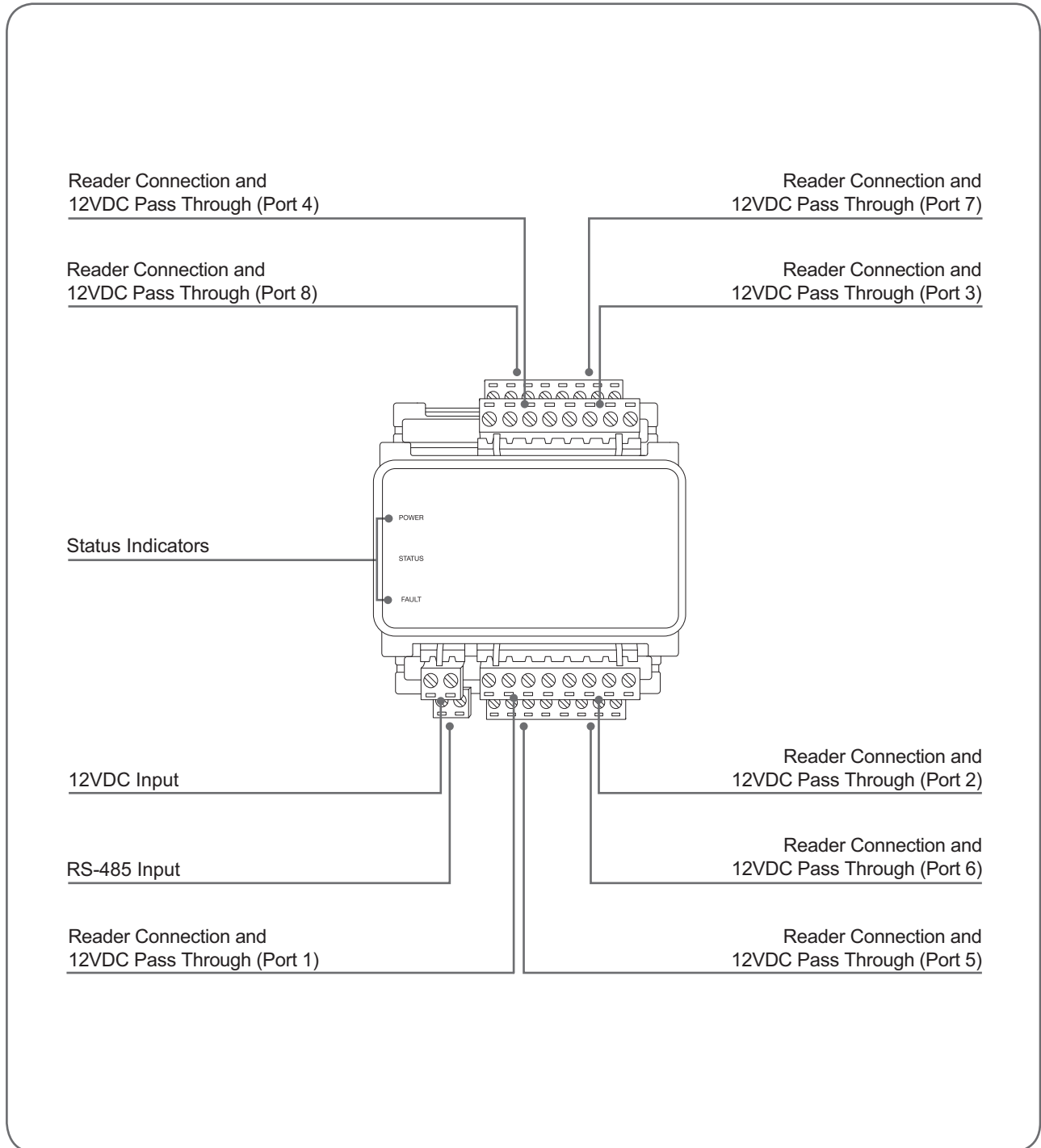

Mechanical Layout

The mechanical layout shown below outlines the essential details needed to help ensure correct installation and mounting. All measurements are shown in millimeters.

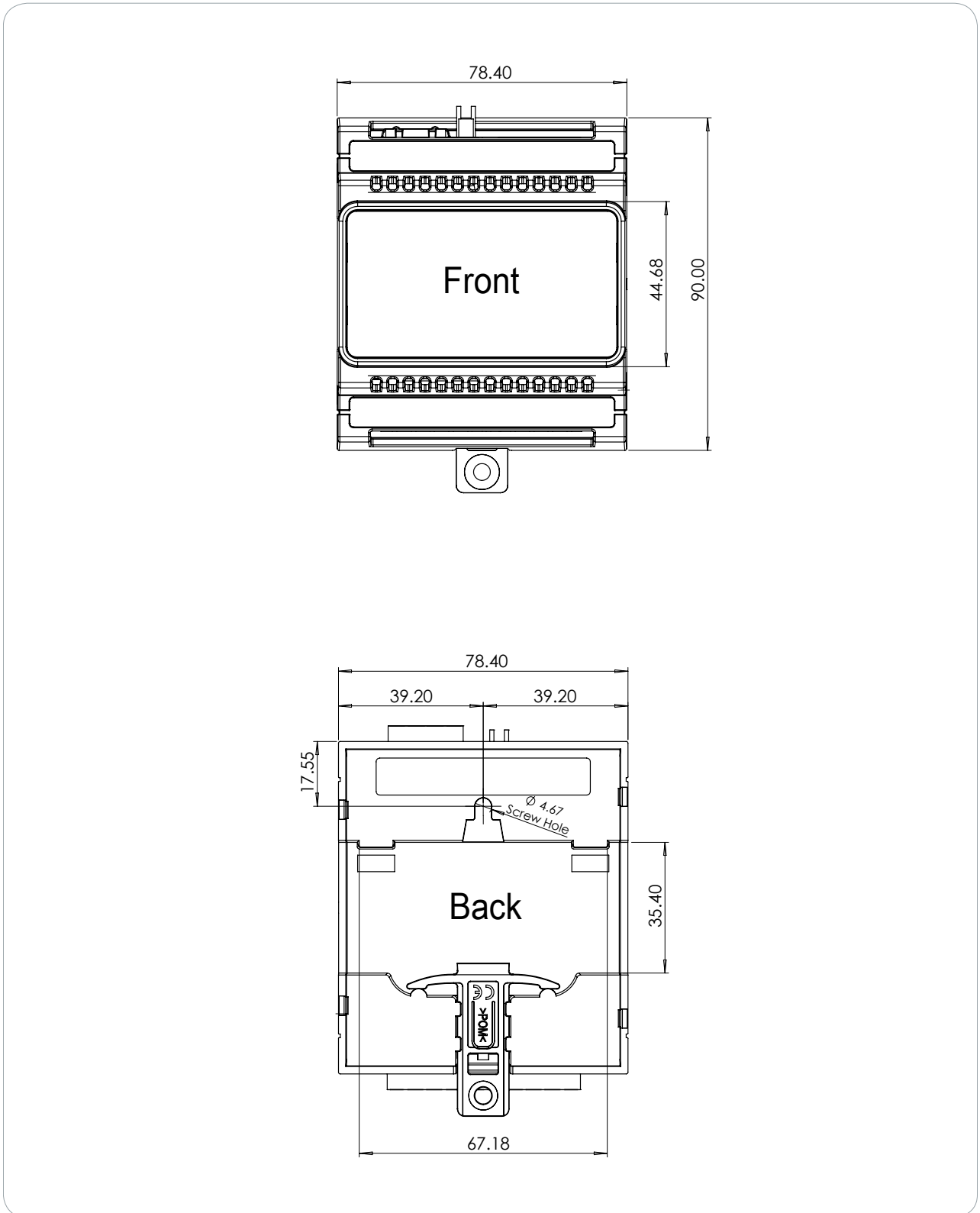

Technical Specifications

The following specifications are important and vital to the correct operation of this product. Failure to adhere to the specifications will result in any warranty or guarantee that was provided becoming null and void.

Ordering Information	
PRT-F2F8-DIN	Protege Half DIN Rail 8 Port F/2F Reader Expander
Power Supply	
DC Input Voltage	11-14VDC
Max Pass Through Current	500mA per Reader Pair (Port 1/2, Port 3/4, Port 5/6, Port 7/8)
Total Combined Current*	2.4A
Max Combined Reader Current	1.25A
Operating Current	50mA (Typical) No outputs connected
Communication	
RS-485	Module network
Readers	
Max combined Reader Current	1.25A
Standard Mode	8 F/2F or Supervised F/2F card reader ports (V+, V-, Data, Door)
Auxiliary Outputs	
Current	8 x 140mA (Max) Sink
Dimensions	
Dimensions (L x W x H)	78 x 90 x 60mm (3.1 x 3.5 x 2.4")
Net Weight	177g (6.2oz)
Gross Weight	246g (8.7oz)
Operating Conditions	
Operating Temperature	-10° to 55°C (14° to 131°F)
Storage Temperature	-10° to 85° C (14° to 185° F)
Humidity	0%-93% non-condensing, indoor use only (relative humidity)
Mean Time Between Failures (MTBF)	622,997 hours (calculated using RDF 2000 (UTE C 80-810) Standard)

* The total combined current refers to the current that will be drawn from the external power supply to supply the expander and any devices connected to its outputs. The auxiliary outputs are directly connected via thermal resettable fuses to the N+ N- input terminals, and the maximum current is governed by the trip level of these fuses.

It is important that the unit is installed in a dry cool location that is not affected by humidity. Do not locate the unit in air conditioning or a boiler room that can exceed the temperature or humidity specifications.

Integrated Control Technology continually strives to increase the performance of its products. As a result these specifications may change without notice. We recommend consulting our website (www.ict.co) for the latest documentation and product information.

New Zealand and Australia

General Product Statement

The RCM compliance label indicates that the supplier of the device asserts that it complies with all applicable standards.



European Standards

CE Statement

Conforms where applicable to European Union (EU) Low Voltage Directive (LVD) 2014/35/EU, Electromagnetic Compatibility (EMC) Directive 2014/30/EU, Radio Equipment Directive (RED) 2014/53/EU and RoHS Recast (RoHS2) Directive: 2011/65/EU + Amendment Directive (EU) 2015/863.

This equipment complies with the rules, of the Official Journal of the European Union, for governing the Self Declaration of the CE Marking for the European Union as specified in the above directive(s).



Information on Disposal for Users of Waste Electrical & Electronic Equipment

This symbol on the product(s) and / or accompanying documents means that used electrical and electronic products should not be mixed with general household waste. For proper treatment, recovery and recycling, please take this product(s) to designated collection points where it will be accepted free of charge.

Alternatively, in some countries you may be able to return your products to your local retailer upon purchase of an equivalent new product.

Disposing of this product correctly will help save valuable resources and prevent any potential negative effects on human health and the environment, which could otherwise arise from inappropriate waste handling.

Please contact your local authority for further details of your nearest designated collection point.

Penalties may be applicable for incorrect disposal of this waste, in accordance with your national legislation.

For business users in the European Union

If you wish to discard electrical and electronic equipment, please contact your dealer or supplier for further information.

Information on Disposal in other Countries outside the European Union

This symbol is only valid in the European Union. If you wish to discard this product please contact your local authorities or dealer and ask for the correct method of disposal.

EN50131 Standards

This component meets the requirements and conditions for full compliance with EN50131 series of standards for equipment classification.

EN 50131-1:2006+A2:2017, EN 50131-3:2009, EN 50131-6:2008+A1:2014, EN 50131-10:2014, EN 50136-1:2012, EN 50136-2:2013, EN 60839-11-1:2013

Security Grade 4

Environmental Class II

Equipment Class: Fixed

Readers Environmental Class: IVA, IK07

SP1 (PSTN – voice protocol)

SP2 (PSTN – digital protocol)

SP6 (LAN – Ethernet) and DP1 (LAN – Ethernet + PSTN)

SP6 (LAN – Ethernet) and DP1 (LAN – Ethernet + USB-4G modem)

Tests EMC (operational) according to EN 55032:2015

Radiated disturbance EN 55032:2015

Power frequency magnetic field immunity tests (EN 61000-4-8)

EN50131

In order to comply with EN 50131-1 the following points should be noted:

- Ensure for Grade 3 or 4 compliant systems, the minimum PIN length is set for 6 digits.
- To comply with EN 50131-1 Engineer access must first be authorized by a user, therefore Installer codes will only be accepted when the system is unset. If additional restriction is required then Engineer access may be time limited to the first 30 seconds after the system is unset.
- Reporting delay –Violation off the entry path during the entry delay countdown will trigger a warning alarm. The warning alarm should not cause a main alarm signal and is not reported at this time. It can be signaled locally, visually and or by internal siren type. If the area is not disarmed within 30 seconds, the entry delay has expired or another instant input is violated, the main alarm will be triggered and reported.
- To comply with EN 50131-1 neither Internals Only on Part Set Input Alarm nor Internals Only on Part Set Tamper Alarm should be selected.
- To comply with EN 50131-1 Single Button Setting should not be selected.
- To comply with EN 50131-1, only one battery can be connected and monitored per system. If more capacity is required, a single larger battery must be used.
- For Security Grade 4 installations, two forms of reporting are required. This can be satisfied using the onboard 2400bps modem included with the modem controller model, or through the incorporation of the PRT-4G-USB cellular modem module into the installation with the non-modem controller model.

Anti Masking

To comply with EN 50131-1 Grade 3 or 4 for Anti Masking, detectors with a separate or independent mask signal should be used and the mask output should be connected to another input.

I.e. Use 2 inputs per detector. One input for alarm/tamper and one input for masking.

To comply with EN 50131-1:

- Do not fit more than 10 unpowered detectors per input,
- Do not fit more than one non-latching powered detector per input,
- Do not mix unpowered detectors and non-latching powered detectors on an input.

To comply with EN 50131-1 the Entry Timer should not be programmed to more than 45 seconds.

To comply with EN 50131-1 the Bell Cut-Off Time should be programmed between 02 and 15 minutes.

EN 50131-1 requires that detector activation LEDs shall only be enabled during Walk Test. This is most conveniently achieved by using detectors with a Remote LED Disable input.

To comply with EN 50131-1, EN 60839-11 Security Grade 4 and AS/NZS2201.1 class 4&5 Vibration Detection for PreTamper Alarm, protection is provided by a DSC SS-102 Shockgard Seismic vibration sensor mounted within the system enclosure. Alarm output is provided by a pair of non-latching, N.C. (normally closed) relay contacts, opening for a minimum of 1 second on detection of an alarm connected in series with the 24Hr tamper input (TP) on the PSU (or any other system input designated/programmed as a 24Hr Tamper Alarm).

This relay is normally energized to give fail-safe operation in the event of a power loss. Indication of detection is provided by a LED situated on the front cover. The vibration sensor is fully protected from tampering by a N.C. micro switch operated by removal of the cover.

Enclosure EN-DIN-24 has been tested and certified to EN50131.

By design, the enclosures for all Integrated Control Technology products, EN-DIN-11, EN-DIN-12 and EN-DIN-24-ATTACK, comply with the EN 50131 standards. Tamper protection against removal of the cover as well as removal from mounting is provided by tamper switch.

Warning: Enclosures supplied by 3rd parties may not be EN50131-compliant, and should not be claimed as such.

UK Conformity Assessment Mark

General Product Statement

The UKCA Compliance Label indicates that the supplier of the device asserts that it complies with all applicable standards.



FCC Compliance Statements

FCC Rules and Regulations CFR 47, Part 15, Subpart B

This equipment complies with the limits for a Class A digital device, pursuant to Part 15 of the FCC rules.

Operation is subject to the following two conditions:

- This device may not cause harmful interference.
- This device must accept any interference received, including interference that may cause undesired operation.

NOTE: THE GRANTEE IS NOT RESPONSIBLE FOR ANY CHANGES OR MODIFICATIONS NOT EXPRESSLY APPROVED BY THE PARTY RESPONSIBLE FOR COMPLIANCE. SUCH MODIFICATIONS COULD VOID THE USER'S AUTHORITY TO OPERATE THE EQUIPMENT.

Industry Canada Statement

ICES-003

This class A digital apparatus complies with Canadian ICES-003.

Cet appareil numérique de la classe A est conforme à la norme NMB-003 du Canada.

CAN ICES-3 (A)/NMB-3(A)

Disclaimer and Warranty

Disclaimer: Whilst every effort has been made to ensure accuracy in the representation of this product, neither Integrated Control Technology Ltd nor its employees shall be liable under any circumstances to any party in respect of decisions or actions they may make as a result of using this information. In accordance with the ICT policy of enhanced development, design and specifications are subject to change without notice.

For warranty information, see our [Standard Product Warranty](#).

Designers & manufacturers of integrated electronic access control, security and automation products.
Designed & manufactured by Integrated Control Technology Ltd.
Copyright © Integrated Control Technology Limited 2003-2026. All rights reserved.

Disclaimer: Whilst every effort has been made to ensure accuracy in the representation of this product, neither Integrated Control Technology Ltd nor its employees shall be liable under any circumstances to any party in respect of decisions or actions they may make as a result of using this information. In accordance with the ICT policy of enhanced development, design and specifications are subject to change without notice.